

WKM[®] DynaCentric[®] High Performance Butterfly Valves

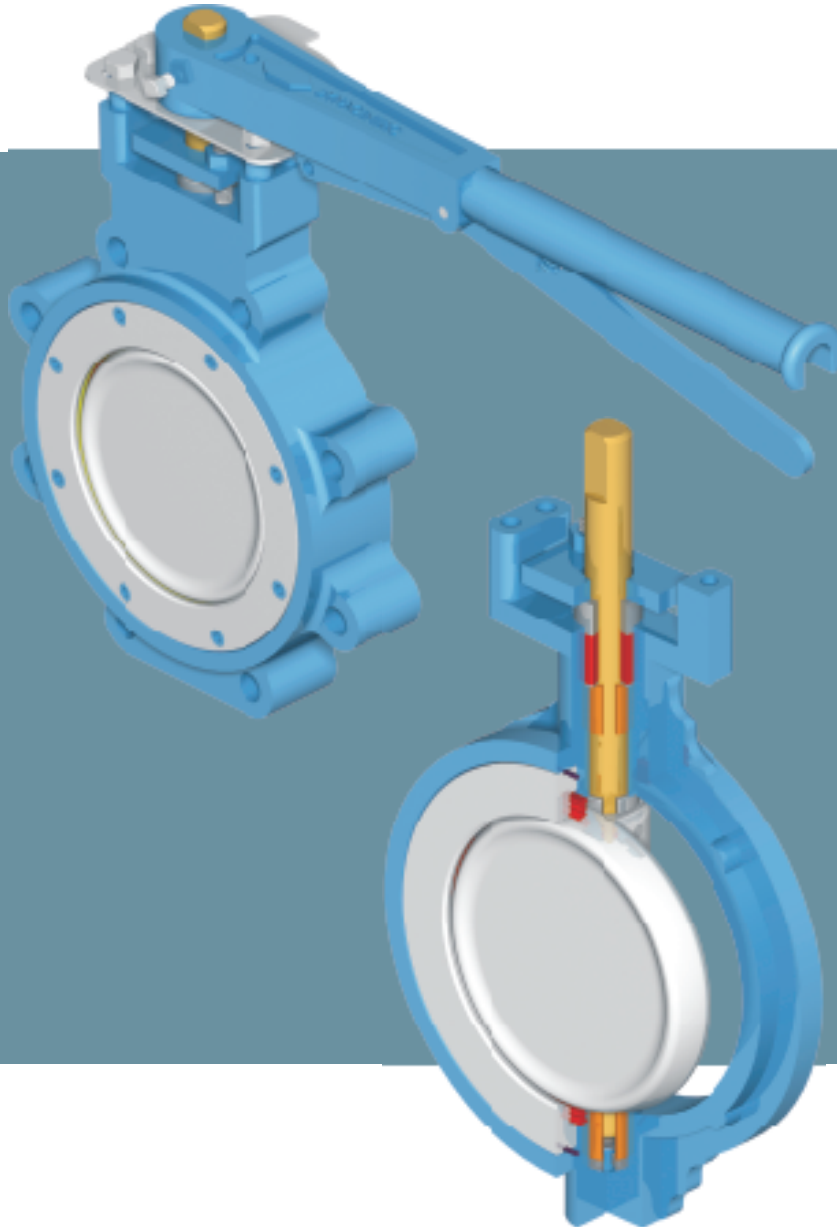

TABLE OF CONTENTS

**WKM DYNACENTRIC
HIGH PERFORMANCE
BUTTERFLY VALVES**

Features and Benefits 2

PRODUCT SPECIFICATIONS

How to Order 6

Standard Materials 7

Seat/Seal Material Codes and Ratings 9

Pressure/Temperature Ratings 10

Valve Sizing Formulas 11

Flow Characteristics 12

Torque Values 13

Dimensional Data 15

Actuators 18

MATERIAL SELECTION GUIDE 19**TRADEMARK INFORMATION** 23

**DYNACENTRIC HIGH PERFORMANCE BUTTERFLY VALVES
FEATURES AND BENEFITS**

MODEL MB-1 (WAFER)

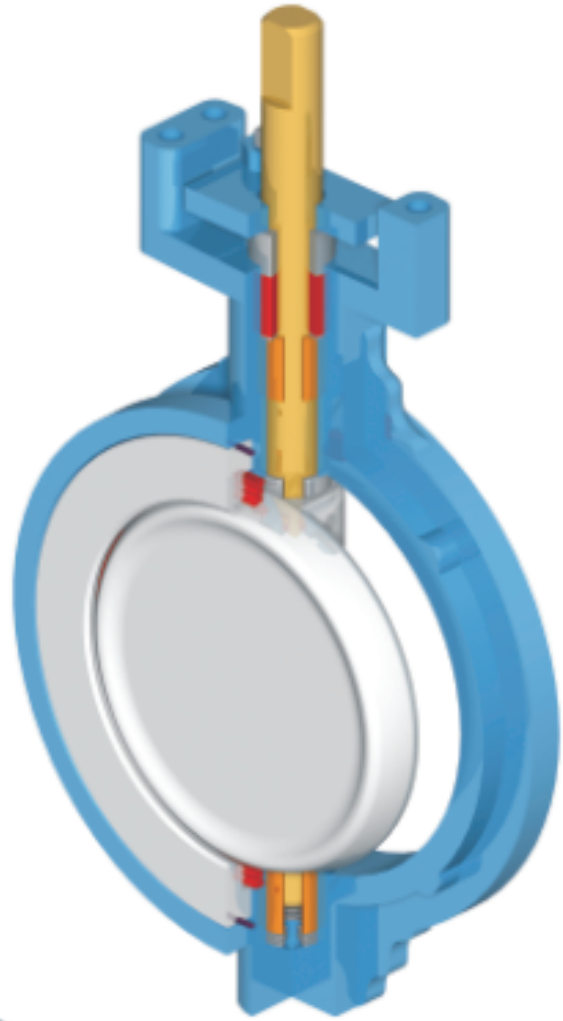

MODEL MB-1 (LUG)

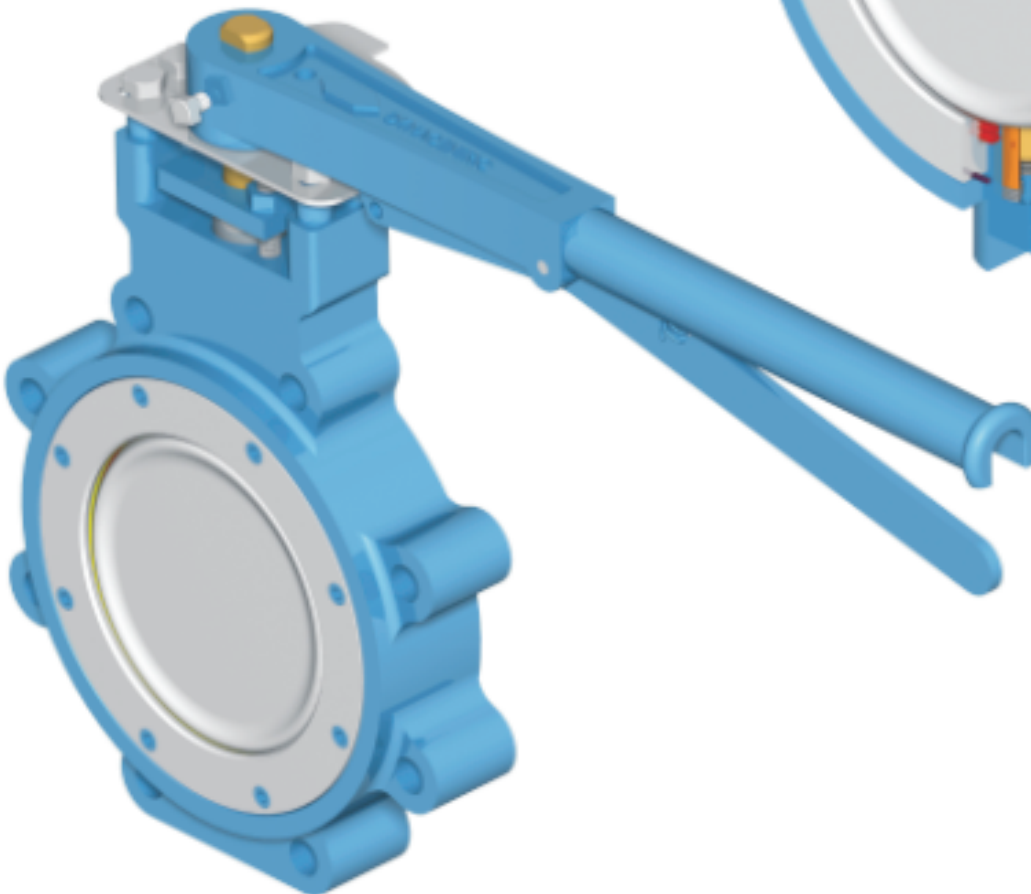

DYNACENTRIC HIGH PERFORMANCE BUTTERFLY VALVES

The DynaCentric High Performance Butterfly Valve brings low cost and light weight to high pressure water, oil, steam, gas and slurry applications.

These valves satisfy a wide range of industrial applications and are available in carbon steel or stainless steel as well as lug and wafer body styles.

DynaCentric High Performance Butterfly Valves offer the high performance of ball and gate valves with the low-cost, lightweight benefits of a butterfly valve design.

Engineered for heavy-duty, maintenance free performance the DynaCentric High Performance Butterfly Valve is most commonly selected for the following applications:

- Chemical & Petrochemical Processing
- Utilities
- Pulp and Paper
- Oil and Gas Production
- Fuel Handling Systems
- Air Conditioning and Refrigeration
- Marine

FEATURES AND BENEFITS

TWO BODY STYLES

- Flangeless Wafer and Threaded Lug styles are available.

HEAVY DUTY DISC

- Designed to withstand the higher stresses associated with high pressure applications. Wide Disc edge provides greater sealing area.

THRUST BEARING/DISC SPACER

- A corrosion resistant, single component Thrust Bearing/Disc spacer reduces body wear and assures positive centering of disc in the valve bore.

INTERNAL STOP

- Prevents disc over-travel and seat damage caused by disc over-travel. Assures proper disc alignment in closed position.

DEEP STUFFING BOX FOR EXTENDED LIFE

Deep stuffing box design includes stainless steel fasteners as standard and is available with TFE Chevron or high temperature compression packing for long life and positive stem seal. Live loaded packing assemblies and double stuffing box with purge/monitor port available upon special request for critical applications.

LOWER STEM DISC SPRING

Lower stem disc springs allow for thermal expansion and provides constant grounding.

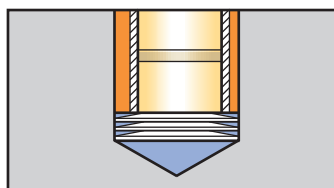
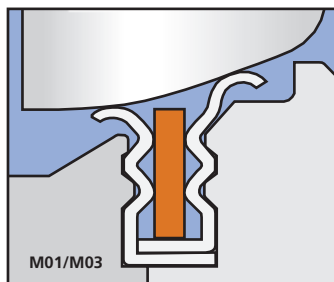
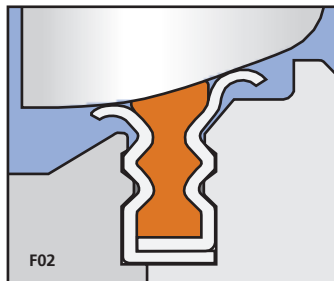
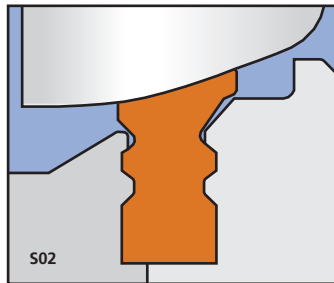
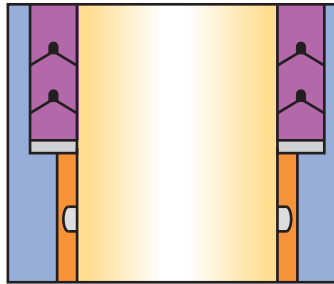
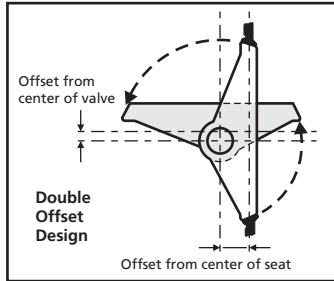

DISC DESIGN REDUCES SEAT WEAR

Precision machined from carbon or alloy steels, the rugged valve disc is designed for gradual engagement into seat to prevent pinching or cutting. Eccentric positioning of stem allows disc to swing free of seat in open position, reducing operating torque and wear.

Special surface coatings such as Stellite overlay are available for critical or severe service conditions.

POSITIVELY RETAINED STEM PREVENTS BLOWOUTS

The tamper-proof design not only meets but exceeds the requirements of ASME B16.34. The disc, disc pins and stem design meet ASME requirements for maximum torsional and bending stress. Additional blowout prevention is provided by stem retainer pins inserted in the stem below the stuffing box.

THREE SEAT DESIGNS

The standard polymer seat (S02) is bi-directional with an extended pressure responsive sealing lip. The S02 seat design is capable of drop tight sealing to 740 psi.

The patented Fire Tested, bi-directional metallic seats with TFE seat insert (F02) provide a Metal-to-Metal pressure responsive triple seal. DynaCentric High Performance Butterfly Valves with the F02 seat design and high temperature seals have been fire tested and are qualified to meet the stringent requirements of API 607 4th Edition. This unique design provides Fire Test capabilities regardless of flow direction. The F02 seat design is capable of drop tight sealing to 1480 psi.

DynaCentric High Performance Butterfly Valves constructed of 316 Stainless Steel and assembled with the proper trims and Ni-Cr Alloy (UNS No. 6625) seats (M03) are capable of handling temperatures to 1000°F (538°C). Metal seats of 316 SS (M01) are suitable for temperatures to 750°F (40°C).

DYNACENTRIC HIGH PERFORMANCE BUTTERFLY VALVES ARE READILY AUTOMATED



SPECIFICATIONS See page 6 for technical specifications

SIZES

- 2 1/2 in. through 36 in. (65 mm through 900 mm)
- Working pressure ASME Class 150, 2 1/2 in. through 36 in. (65 mm through 900 mm)
- ASME Class 300, 2 1/2 in. through 24 in. (65 mm through 600 mm)
- ASME Class 600, 3 in. through 12 in. (80 mm through 300 mm)

OPERATING TEMPERATURES

- Up to 1000°F (538°C)

BODY STYLES

- Flangeless Wafer, Threaded Lug

STANDARD MATERIALS

- Body - Carbon Steel, Stainless Steel
- Stem - 17-4 Stainless Steel
- Disc - Stainless Steel
- Seat - S02 - RTFE
F02 - Fire Tested
M01/ M03 - Metal Seat

OPTIONAL MATERIALS

- Seat/Seal Trims available for hundreds of different ladings. Additional Materials listed on page 6.

DYNACENTRIC HIGH PERFORMANCE BUTTERFLY VALVES SPECIAL SERVICE VALVES

HIGH TEMPERATURE

DynaCentric High Performance Butterfly Valves for High Temperature Service are equipped with a 316 Stainless Steel Seat (M01), 316 Stainless Steel Stem Bearings and High Temperature Seals.

This seat/seal combination is rated up to 750°F (399°C) in Carbon Steel Bodies. Ni-Cr Alloy (UNS No. 6625) seats (M03) and Stainless Steel Bodies can be utilized up to 1000°F (538°C). Leakage rates for metal seated valves can be provided within the service limits of ASME/FCI 70-2 Class V on request.

Standard leakage rate of metal seated valves is less than .005 ml/psi/NPS.

DynaCentric Butterfly Valves furnished with this seat perform well in steam, hot oil and heat transfer fluids.

VACUUM SERVICE

The drop-tight sealing capabilities of DynaCentric High Performance Butterfly Valves make them an excellent selection for vacuum service.

S01, S02, and F02 Seat-Seal codes are suitable for vacuum service to 20 microns absolute.

Inverted Packing or Purged Stuffing Box configuration is available on request.

SOUR OIL AND GAS SERVICE

DynaCentric High Performance Butterfly Valves with sour gas trims are available for H₂S service in accordance with NACE MR0175, 2002.

LOW TEMPERATURE SERVICE

DynaCentric High Performance Butterfly Valves for temperatures to -50°F (-46°C) are available in both 316 Stainless Steel construction and Low Temperature Carbon Steel.

OXYGEN SERVICE

DynaCentric High Performance Butterfly Valves provide the positive Shut-Off and tight sealing necessary for gaseous oxygen service. Due to the risk of explosion and fire inherent in such service, positive grounding for the disc and stem with the Belleville Disc Springs are standard.

Positive safeguards have been established in order to conform to the requirement that valves for Oxygen Service must be completely free of oil, grease, combustible material, slag, metal shavings, paint, rust or various fibers.

All parts are cleaned of contaminants with solvent and inspected under black light.

After assembly and testing with nitrogen, each valve is individually tagged and sealed in a polyethylene bag.

Valves for such service may be supplied in most materials, but 316 Stainless Steel or Ni-Cu Alloy (UNS No. 5500) are recommended.

STEAM SERVICE

DynaCentric High Performance Butterfly Valves are ideally suited for applications in steam service. Reinforced TFE seats (S02) with High Temperature Packing are the standard stem service seal materials.

For higher saturation pressures, 316 Stainless Steel seats with reinforced TFE inserts (F02) are available.

The combination of rotary operation, streamlined flow and positive Shut-Off can result in years of maintenance free service without the seizures on cool-down, flashing or stem leakage associated with conventional globe or gate valves.

ENHANCED FUGITIVE EMISSION CONTROL

The valve Stuffing Box can be modified for live loaded packing assemblies, or include a Double Stuffing Box with Purge/Monitor Port.



Chemical Processing



Pulp and Paper



Power Generation

DYNACENTRIC HIGH PERFORMANCE BUTTERFLY VALVES STANDARDS AND COMPLIANCE

DYNACENTRIC HIGH PERFORMANCE BUTTERFLY VALVES COMPLY WITH THE FOLLOWING DESIGN AND TESTING STANDARDS:

- ASME B16.5 (Steel Pipe Flanges and Flange Fittings)
- ASME B16.34 (Steel Valves)
- ASME/FCI 70-2 (Control Valve Seat Leakage)
- MSS-SP-6 (Standard Finishes for Pipe Flanges)
- MSS-SP-25 (Standard Marking System for Valves)
- MSS-SP-55 (Quality Standard for Steel Castings)
- MSS-SP-68
- CE PED (Pressure Equipment Directive) 97/23/EC

In addition, DynaCentric High Performance Butterfly Valves can be supplied to comply with these standards:

- ASME B31.1 (Power Piping)
- ASME B31.3 (Chemical Plant and Petroleum Refinery Piping)
- MSS-SP-61 (Pressure Testing of Steel Valves)
- API 609, API 598 (Valve Inspection and Testing)
- API 607 4th Edition (Fire Test Specifications)

DynaCentric High Performance Butterfly Valves trimmed for sour gas service in accordance with NACE MR0175, 2002 are available in both Carbon Steel and Alloy construction.

HOW TO ORDER

X X	-	A5* X X X B5* X X X	-	X X	-	X X X	-	X X	/	X X
Size in. (mm)		Body Group		Trim Group		Seal Group		Packing Group ⁴		Actuation

2 1/2 (65)	2 1/2	<table border="1"> <tr><th>Class</th><th>Material</th><th>Style</th></tr> <tr><td>1 = 150</td><td>1 = CS</td><td>0 = Wafer** 2 1/2" - 12" Slip in Seat Retainer</td></tr> <tr><td>3 = 300</td><td>2 = SS</td><td>1 = Lug Model A (Class 600) Bolted Seat Retainer</td></tr> <tr><td>6 = 600</td><td>3 = CS2¹</td><td>2 = Wafer 14" - 24" Bolted Seat Retainer</td></tr> <tr><td></td><td></td><td>3 = Lug Model B Bolted Seat Retainer</td></tr> <tr><td></td><td>4 = CS/ENC</td><td></td></tr> <tr><td></td><td>5 = LCC</td><td></td></tr> </table>	Class	Material	Style	1 = 150	1 = CS	0 = Wafer** 2 1/2" - 12" Slip in Seat Retainer	3 = 300	2 = SS	1 = Lug Model A (Class 600) Bolted Seat Retainer	6 = 600	3 = CS2 ¹	2 = Wafer 14" - 24" Bolted Seat Retainer			3 = Lug Model B Bolted Seat Retainer		4 = CS/ENC			5 = LCC		<table border="1"> <tr><td>CS Disc⁵ 17-4 Stem</td><td>01</td></tr> <tr><td>SS Disc 17-4 Stem</td><td>02</td></tr> <tr><td>SS Disc Ni-Cr⁶ Stem</td><td>03</td></tr> <tr><td>Ni-Cu⁷ Disc & Stem</td><td>04</td></tr> <tr><td>SS Disc 316 SS Stem²</td><td>05</td></tr> <tr><td>SS Disc HF-6 O/L⁸ 17-4 Stem</td><td>06</td></tr> <tr><td>SS Disc HF-6 O/L⁸ Ni-Cr Stem⁶</td><td>07</td></tr> </table>	CS Disc ⁵ 17-4 Stem	01	SS Disc 17-4 Stem	02	SS Disc Ni-Cr ⁶ Stem	03	Ni-Cu ⁷ Disc & Stem	04	SS Disc 316 SS Stem ²	05	SS Disc HF-6 O/L ⁸ 17-4 Stem	06	SS Disc HF-6 O/L ⁸ Ni-Cr Stem ⁶	07	<table border="1"> <tr><td>TFE VEE</td><td>11</td></tr> <tr><td>High Temp Graphitized</td><td>13</td></tr> <tr><td>Grafoil</td><td>14</td></tr> </table>	TFE VEE	11	High Temp Graphitized	13	Grafoil	14	<table border="1"> <tr><td>Bare Stem</td><td>00</td></tr> <tr><td>Handle</td><td>HL</td></tr> <tr><td>Handwheel Worm Gear</td><td>WG</td></tr> <tr><td>Less Gear with Flange</td><td>FG</td></tr> <tr><td>Chainwheel</td><td>CH</td></tr> </table>	Bare Stem	00	Handle	HL	Handwheel Worm Gear	WG	Less Gear with Flange	FG	Chainwheel	CH
Class	Material		Style																																																					
1 = 150	1 = CS		0 = Wafer** 2 1/2" - 12" Slip in Seat Retainer																																																					
3 = 300	2 = SS		1 = Lug Model A (Class 600) Bolted Seat Retainer																																																					
6 = 600	3 = CS2 ¹		2 = Wafer 14" - 24" Bolted Seat Retainer																																																					
			3 = Lug Model B Bolted Seat Retainer																																																					
	4 = CS/ENC																																																							
	5 = LCC																																																							
CS Disc ⁵ 17-4 Stem	01																																																							
SS Disc 17-4 Stem	02																																																							
SS Disc Ni-Cr ⁶ Stem	03																																																							
Ni-Cu ⁷ Disc & Stem	04																																																							
SS Disc 316 SS Stem ²	05																																																							
SS Disc HF-6 O/L ⁸ 17-4 Stem	06																																																							
SS Disc HF-6 O/L ⁸ Ni-Cr Stem ⁶	07																																																							
TFE VEE	11																																																							
High Temp Graphitized	13																																																							
Grafoil	14																																																							
Bare Stem	00																																																							
Handle	HL																																																							
Handwheel Worm Gear	WG																																																							
Less Gear with Flange	FG																																																							
Chainwheel	CH																																																							
3 (80)	03																																																							
4 (100)	04																																																							
5 (125)	05																																																							
6 (150)	06																																																							
8 (200)	08																																																							
10 (250)	10																																																							
12 (300)	12																																																							
14 (350)	14																																																							
16 (400)	16																																																							
18 (450)	18																																																							
20 (500)	20																																																							
24 (600)	24																																																							
30 (750)	30																																																							
36 (900)	36																																																							

TFE	S01
RTFE	S02
SS/RTFE	F02 ³
Ni-Cr ⁶ Alloy (UNS No. 6625)/RTFE	F03
316 SS	M01
Ni-Cr ⁶ Alloy (UNS No. 6625)	M03

*** MODEL/SIZE AVAILABILITY:**

Model B 2 1/2 in. & 5 in. (65 mm & 125 mm) Class 150 & Class 300 Lug
 4 in. & 6 in. (100 mm & 150 mm) through 24 in. (600 mm)
 Class 150 & Class 300 Lug & Wafer
 3 in. (80 mm) Class 150, Class 300 & Class 600 Lug & Wafer
 36 in. (900 mm) Class 150 Lug

Model A 4 in. & 6 in. (100 mm & 150 mm) through 12 in. (300 mm)
 Class 600 Lug & Wafer
 30 in. (750 mm) Class 150 Lug

** Wafer Valves 2 1/2 in. - 12 in. (65 mm - 300 mm) come standard with an unbolted inset seat retainer, held firmly in place for shipping and handling by an interference fit O-ring retention design (see page 2). By design, the seat retainer is secured in place by the piping flange during normal installation procedure.

- Controlled hardness Carbon Steel (H₂S Service).
- Valves equipped with 316 SS stems may require derating depending on size and class. See page 10 for actual valve ratings.
- Standard Seat for Class 600 valves.
- Stainless Steel packing adjustment studs and nuts are standard.
- Carbon Steel Discs 14 in. (350 mm) & larger - consult factory.
- Reference Inconel.
- Reference Monel.
- Reference Stellite overlay.

Note: Other materials of construction and valve options are available on application.

MB-1 DYNACENTRIC HIGH PERFORMANCE BUTTERFLY VALVES
 2 1/2 in. THROUGH 24 in. (65 mm THROUGH 600 mm) ASME CLASSES 150 & 300
 3 in. (80 mm) ASME CLASS 600
 36 in. (900 mm) ASME CLASS 150
MATERIALS LIST

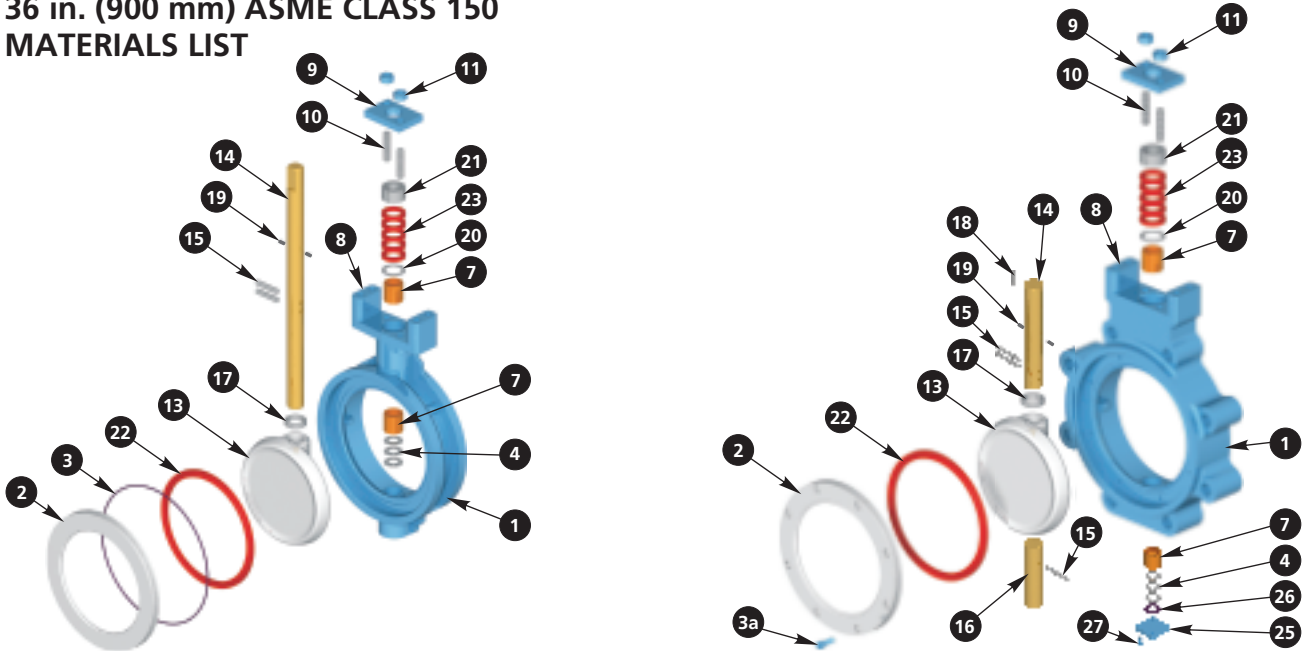

BODY GROUP TRIM NUMBER

PART	CARBON STEEL	STAINLESS STEEL	CARBON STEEL (H ₂ S)
1 Body	A216 Gr. WCC	A351 Gr. CF8M	A216 Gr. WCC RC-22
2 Seat Retainer	A516 Gr. 70	A487 Gr. 4	A516 Gr. 70 RC-22
3 Seat Retainer O-Ring	Nitrile	Nitrile	Nitrile
3a Seat Retainer Screw	A193 Gr. B7	18-8 SS	18-8 SS
4 Stem/Disc Spring	18-8 SS	18-8 SS	18-8 SS
7 Stem Bearing	TFE/Steel	Teflon/316 SS	Teflon/316 SS
8 Nameplate	18-8 SS	18-8 SS	18-8 SS
9 Gland Retainer	Carbon Steel	Stainless Steel	Carbon Steel
10 Gland Retainer Stud	18-8 SS	18-8 SS	18-8 SS
11 Gland Retainer Nut	18-8 SS	18-8 SS	18-8 SS
25 Bottom Cover	Carbon Steel	Stainless Steel	Carbon Steel RC-22
26 Bottom Cover Gasket	Composite Fiber	Composite Fiber	Composite Fiber
27 Bottom Cover Screw	A193 Gr. B7	18-8 SS	A193 Gr. B7

INTERNAL GROUP TRIM NUMBER

13 Disc	A351 Gr. CF8M*	A351 Gr. CF8M*	A351 Gr. CF8M*
▲ 14 Upper Stem	—————	A564 Type 630, H1150 + H1150	—————
15 Stem Pins	—————	A564 Type 630, H1150 + H1150	—————
▲ 16 Lower Stem	—————	A564 Type 630, H1150 + H1150	—————
17 Disc Spacer	316 SS	316 SS	316 SS
18 Stem Key (8 in. (200 mm) and larger)	Carbon Steel	Carbon Steel	Carbon Steel
19 Stem Retainer Pins	316 SS	316 SS	316 SS
20 Packing Spacer	316 SS	316 SS	316 SS
21 Gland Ring	316 SS	316 SS	316 SS

SEAL GROUP TRIM CODE (Note Pressure Classes)

22 Seat	————— See Note (1) —————
23 Packing Set	————— TFE VEE, High Temperature, Graphitized or Grafoil —————

Note (1) Seat assemblies consist of the following:
 TYPE S - Class 150 - Virgin TFE (available in Class 150 only) Standard Class 150 and 300 - Reinforced TFE
 TYPE F - Metal, Fire Tested, Class 150, 300 and 600 - Stainless Steel with Reinforced TFE Insert - STD Seat for all Class 600 Valves
 TYPE M - Metal, High Temperature, Class 150, 300 and 600 - 316 Stainless Steel with 316 Stainless Steel Insert.

* Hard Chrome Plated on F02, M01 and M03.
 ▲ One-Piece Stem 2 1/2 in. (65 mm) through 12 in. (300 mm) Class 300.
 Two-Piece Stem 12 in. (300 mm) Class 600 through 36 in. (900 mm) Class 150.
 TYPICAL VALVE CONSTRUCTION SHOWN - SOME SIZES MAY VARY.

MA-1 DYNACENTRIC HIGH PERFORMANCE BUTTERFLY VALVES

4 in., 6 in., 8 in., 10 in., 12 in. (100 mm, 150 mm, 200 mm, 250 mm, 300 mm) ASME CLASS 600
 30 in. (750 mm) ASME CLASS 150

MATERIALS LIST

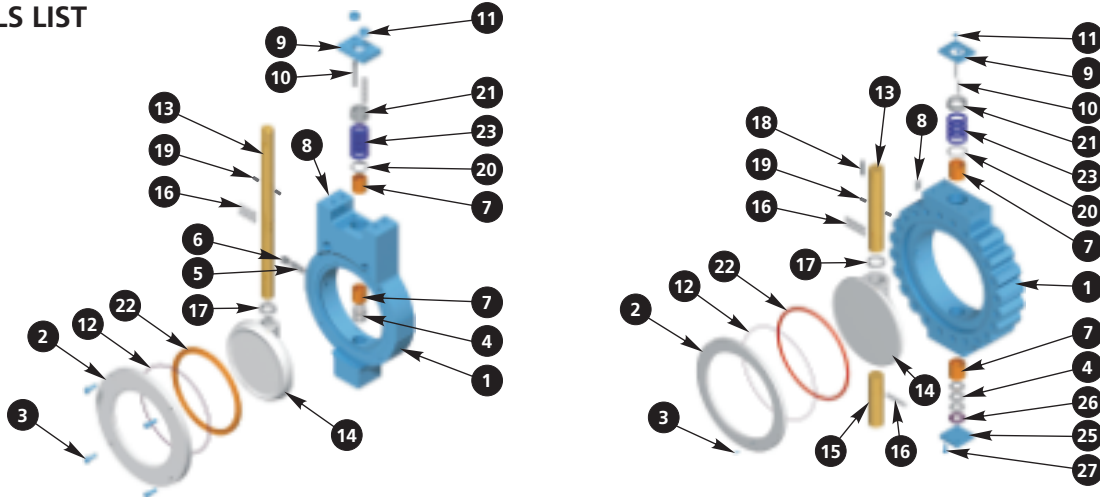

BODY GROUP TRIM NUMBER

PART	CARBON STEEL	STAINLESS STEEL	CARBON STEEL (H ₂ S)
1 Body	A216 Gr. WCC	A351 Gr. CF8M	A216 Gr. WCC RC-22
2 Seat Retainer	A516 Gr. 70	A276 Type 316	A516 Gr. 70 RC-22
3 Seat Retainer Screw	A193 Gr. B7	18-8 SS	18-8 SS
4 Stem/Disc Spring	18-8 SS	18-8 SS	18-8 SS
5 Stop Pin (4 in. (100 mm) through 10 in. (250 mm) only)	316 SS	316 SS	316 SS
6 Stop Pin Plug (4 in. (100 mm) through 10 in. (250 mm) only)	Carbon Steel	316 SS	316 SS
7 Stem Bearing	Teflon/Steel	Teflon/316 SS	Teflon/316 SS
8 Nameplate	18-8 SS	18-8 SS	18-8 SS
9 Gland Retainer	Carbon Steel	Stainless Steel	Carbon Steel
10 Gland Retainer Stud	18-8 SS	18-8 SS	18-8 SS
11 Gland Retainer Nut	18-8 SS	18-8 SS	18-8 SS
12 Body Gasket	See Note (2)		
25 Bottom Cover Plate	Carbon Steel	Stainless Steel	Carbon Steel
26 Bottom Cover Gasket	Composite Fiber	Composite Fiber	Composite Fiber
27 Bottom Cover Screw	A193 Gr. B7	18-8 SS	A193 Gr. B7

INTERNAL GROUP TRIM NUMBER

▲ 13 Upper Stem	A564 Type 630, H1150 + H1150		
14 Disc	A216 Gr. WCC** A351 Gr. CF8M*	A351 Gr. CF8M*	A351 Gr. CF8M*
▲ 15 Lower Stem	A564 Type 630, H1150 + H1150		
16 Stem Pins	A564 Type 630, H1150 + H1150		
17 Disc Spacer	316 SS	316 SS	316 SS
18 Stem Key (6 in. (150 mm) and larger)	Carbon Steel	Carbon Steel	Carbon Steel
19 Stem Retainer Pins	316 SS	316 SS	316 SS
20 Packing Spacer	316 SS	316 SS	316 SS
21 Gland Ring	316 SS	316 SS	316 SS

SEAL GROUP TRIM CODE (Note Pressure Classes)

22 Seat	See Note (1)
23 Packing Set	TFE VEE, High Temperature, Graphitized or Grafoil

Note (1) Seat assemblies consist of the following:

- TYPE S - Class 150 only - Virgin TFE, Class 150 and 300 - Reinforced TFE
- TYPE F - Metal, Fire Tested, Class 150, 300 and 600 - Stainless Steel with Reinforced TFE Insert - STD Seat for all Class 600 Valves
- TYPE M - Metal, High Temperature, Class 150, 300 and 600 - 316 Stainless Steel with 316 Stainless Steel Insert.

Note (2) Standard valves do not require Body Gaskets. F02 Fire Tested, Fire Safe and High Temperature, M01/M03 valves are equipped with Composite Fiber Body Gaskets.

* Hard Chrome Plated on F02, M01 and M03.

** Electroless Nickel Plated 14 in. through 30 in. (350 mm through 750 mm).

▲ One-Piece Stem 2 1/2 in. (65 mm) through 12 in. (300 mm) Class 300. Two-Piece Stem 12 in. (300 mm) Class 600 through 36 in. (900 mm) Class 150.

TYPICAL VALVE CONSTRUCTION SHOWN - SOME SIZES MAY VARY

DYNACENTRIC HIGH PERFORMANCE BUTTERFLY VALVES SEAT SEAL MATERIAL CODES AND RATINGS

MATERIAL CODES

This chart is an abbreviated guide to the chemical resistance and pressure temperature limitations of seat seal materials used in DynaCentric High Performance Butterfly Valves.

Complete ratings curves are shown below.

For additional information, please consult your DynaCentric representative or the factory.

SEAL CODE	SEAT MATERIAL	ASME/FCI 70-2 SHUTOFF CLASS	SERVICE APPLICATION
S01	TFE	6 (VI)	Seats are virgin TFE. Use where lading contamination from glass or other fillers is not desirable, such as in food service. Available in Class 150 valves only. Temperature range is -50°F to 400°F (-46°C to 204°C). Drop tight.
S02	RTFE	6 (VI)	Seat material is TFE reinforced with inert materials for use at elevated temperatures and pressures. Same chemical resistance as Virgin TFE except slightly affected by hot alkaline solutions. Suitable for saturated steam to 200 psig.** Temperature range is -50°F to 500°F (-46°C to 260°C). Drop tight.
F02	SS/RTFE	6 (VI)	Seat consists of Stainless Steel Rings with a reinforced TFE insert. Recommended trim for Fire Test Applications and for Higher Pressure Steam Service.** Temperature is -50°F to 500°F (-46°C to 260°C). Drop tight.
F03	Ni-Cr Alloy (UNS No. 6625)/RTFE	6 (VI)	Seat consists of Ni-Cr Alloy (UNS No. 6625) with a reinforced TFE insert. Recommended trim for Fire Test Applications and for Higher Pressure Steam Service.** Temperature range is -50°F to 500°F (-46°C to 260°C). Drop tight.
M01	316 SS	*	Recommended trim for saturated steam above 250 psi, hot oils and gases and temperatures to 750°F (399°C). Pressure/temperature range is same as body rating. Meets ASME/FCI 70-2.
M03	Ni-Cr Alloy (UNS No. 6625)	*	Same as M01 but for temperatures from 750°F to 1000°F (399°C to 538°C).

* Standard leakage rate of metal seated valves is less than .005 ml/psi/NPS. Class V Shut-Off can be furnished on request.

** Consult factory for steam applications with higher pressure.

Pressure-Temperature Limitations

Seat ratings are based on differential pressures with the disc in the FULLY CLOSED position and refer to seat only. Body pressure/temperature ratings appear on page 10.

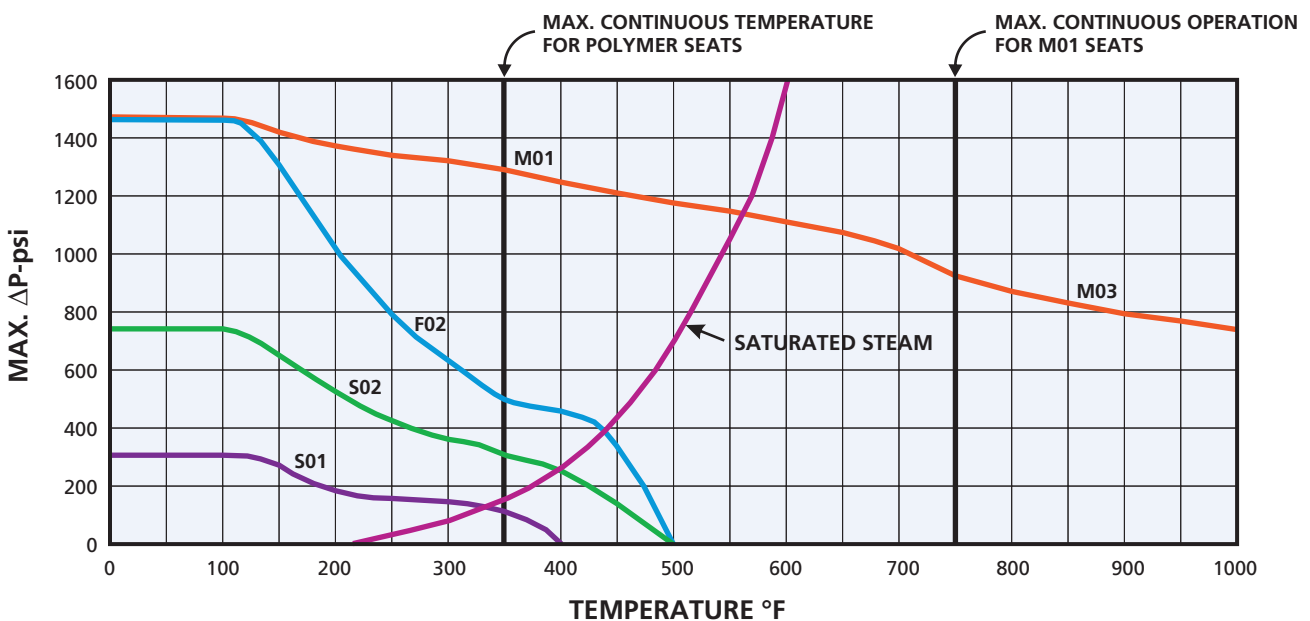

DYNACENTRIC HIGH PERFORMANCE BUTTERFLY VALVES VALVE BODY PRESSURE RATINGS

PRESSURE/TEMPERATURE RATINGS FOR DYNACENTRIC VALVE BODIES WITH STANDARD STEMS

TEMP °F	CLASS 150		CLASS 300		CLASS 600	
	CS	316 SS	CS	316 SS	CS	316 SS
-20 to 100	285	275	740	720	1480	1440
200	260	235	675	620	1350	1240
300	230	215	655	560	1315	1120
400	200	195	635	515	1270	1025
500	170	170	600	480	1200	955
600	140	140	550	450	1095	900
650	125	125	535	445	1075	890
700	110	110	535	430	1065	870
750	95	95	505	425	1010	855
800	80	80	410	420	825	845
850	-	65	-	420	-	835
900	-	50	-	415	-	830
950	-	35	-	385	-	775
1000	-	20	-	350	-	700

Stem Material: A564 Type 630, H1150 + H1150.
In accordance with ASME B16.34.

Ratings shown above are maximum working pressure ratings for the valve body at various temperatures.

All pressures are psig.

Practical pressure limitations according to actual service conditions are determined by the seat ratings shown on page 9.

These valve body ratings are based on the following material specifications:

CS-ASTM A516 Grade 70 and A216 Grade WCC

NOTE: Carbon Steel listed is not recommended for prolonged usage above 800°F (427°C)

316 SS-ASTM A351 Grade CF8M.

MAXIMUM SHUT-OFF PRESSURE FOR DYNACENTRIC VALVES 316 STAINLESS STEEL STEMS (CWP)

SIZE in.	(mm)	ΔP MAX.-316 SS STEMS		
		CLASS 150	CLASS 300	CLASS 600
21/2	(65)	285	740	-
3	(80)	285	740	650
4	(100)	285	285	650
5	(125)	285	720	-
6	(150)	285	400	650
8	(200)	285	450	650
10	(250)	180	500	650
12	(300)	250	740	650
14	(350)	200	740	-
16	(400)	285	740	-
18	(450)	285	740	-
20	(500)	285	740	-
24	(600)	285	740	-
30	(750)	285	-	-
36	(900)	285	-	-

Stem Material: ASTM A276 Type 316; Cond. A.
30,000 Minimum Yield
75,000 Minimum Tensile

Valves with 17-4 PH stems are only recommended up to a maximum temperature of 650°F (343°C).

Ni-Cr Alloy (UNS No. 7718) stems are required for temperatures above 650°F (343°C).

NOTE: Cold working pressures for the DynaCentric Valves equipped with 316 SS stems will be derated.

See table above.

Ni-Cr Alloy (UNS No. 7718) or Ni-Cu Alloy (UNS No. 5500) stems can be furnished for applications requiring high corrosion resistance and full ASME ratings.

DYNACENTRIC HIGH PERFORMANCE BUTTERFLY VALVES VALVE SIZING FORMULAS

Proper valve selection is dependent on several factors for both liquid and gas flow, as well as the physical limitations of the valve as established by the manufacturer.

The following information is presented for handy and quick reference.

The flow coefficient (C_v) is the most universally accepted measure of a valve's capacity to handle flow.

A dimensionless entity, C_v is defined as the number of gallons per minute of water at standard conditions (60°F (16°C) and 14.7 psia) which will flow through a given flow restriction with a pressure drop of 1 psi.

Once determined, the C_v of a valve provides a capacity index by which one is able to readily estimate the required size of a flow restriction for controlling the fluid flow of any system.

For liquid service:

$$C_v = Q_L \sqrt{\frac{S_G}{\Delta P}}$$

$$Q_L = C_v \sqrt{\frac{\Delta P}{S_G}}$$

$$\Delta P = S_G \left(\frac{Q_L}{C_v} \right)^2$$

For gas service:

$$C_v = \frac{Q_G}{1360} \sqrt{\frac{S_G T_R}{\Delta P \times P_1}}$$

$$Q_G = 1360 C_v \sqrt{\frac{\Delta P \times P_1}{S_G T_R}}$$

$$\Delta P = \frac{S_G T_R}{P_1} \left(\frac{Q_G}{1360 C_v} \right)^2$$

For steam service (saturated):

$$C_v = \frac{W}{2.1 \sqrt{\Delta P (P_1 + P_2)}}$$

$$W = 2.1 C_v \sqrt{\Delta P (P_1 + P_2)}$$

For steam service (superheated):

$$C_v = \frac{W(1 + 0.0007 T_s)}{2.1 \sqrt{\Delta P (P_1 + P_2)}}$$

$$W = \frac{2.1 C_v \sqrt{\Delta P (P_1 + P_2)}}{(1 + 0.0007 T_s)}$$

These formulas are generally accurate for gas flow where $\Delta P \leq .1P_1$.

For $\Delta P > .1P_1$, consult factory for assistance in sizing.

Where:

- C_v = valve flow coefficient
- P_1 = upstream pressure, psia
- P_2 = downstream pressure, psia
- ΔP = pressure drop $P_1 - P_2$, psi
- Q_G = gas flow rate, SCFH
- Q_L = liquid flow rate, U.S. gpm
- S_G = specific gravity of fluid
- T_R = temperature, °R (460 + °F)
- T_s = steam superheat, °F
- W = flow rate, lbs/hr
- P_v = vapor pressure, psia

Cavitation

DynaCentric High Performance Butterfly Valves, because of their inherently high flow capacities, have a greater tendency to cavitate at high pressure drops.

Cavitation occurs in liquids if the static pressure of the flowing liquid decreases to a value less than the fluid under pressure. This phenomenon can create accelerated wear and deterioration of valves and piping as well as annoying noise and vibration problems.

To avoid cavitation in piping, the following formula should be employed:

$$\Delta P_{\max} = 0.33 (P_1 - P_v).$$

This formula can also be safely used where reducers are employed.

Reducers

When valves are mounted between pipe reducers, a loss in valve capacity occurs with an additional pressure drop across the system due to contractions and sudden enlargements.

This arrangement is often employed with DynaCentric High Performance Butterfly Valves where the desired C_v for the control valve results in a valve size that is smaller than the line size.

Use the following equation to obtain the corrected flow coefficients for the DynaCentric High Performance Butterfly Valve when installed in combination with reducers.

$$R = \frac{1}{\sqrt{1 + \frac{1.5 \left(1 - \frac{d^2}{D^2}\right)^2}{890} \left(\frac{C_v}{d^2}\right)^2}} \quad C_{vR} = C_v R$$

Where:

- C_v = sizing coefficient determined by standard calculations
- d = nominal valve size, inches
- D = line size, inches

DYNACENTRIC HIGH PERFORMANCE BUTTERFLY VALVES FLOW CHARACTERISTICS (C_v)

The practical control range of this type of valve occurs where continuous throttling can be effected without significant loss of accuracy or decrease in valve life.

The usable rangeability for DynaCentric High Performance Butterfly Valves is between 20° and 70° opening, resulting in a ratio of 10:1.

In sizing the DynaCentric High Performance Butterfly Valve for throttling applications, a full open C_v should be selected that is approximately 1.8 times the C_v determined from calculations.

Under normal flow conditions, this selection will provide a valve opening of 50°-60°.

C_v values equal the flow of water in U.S. gallons per minute per 1 psi pressure drop.

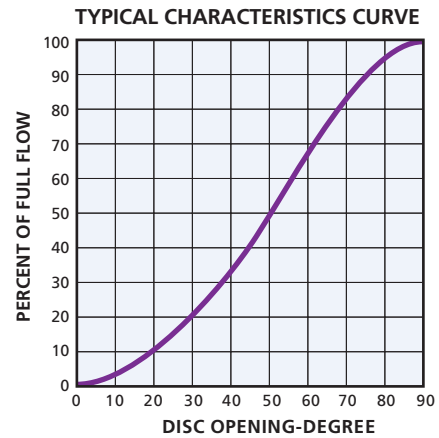

SERIES 5100 CLASS 150

VALVE SIZE		DISC ANGLE, DEGREES OPEN							
in.	(mm)	20	30	40	50	60	70	80	90
2 1/2	(65)	8	17	31	46	66	82	97	103
3	(80)	14	31	54	81	115	144	169	180
4	(100)	31	66	117	176	250	312	367	400
5	(125)	54	114	201	302	429	536	630	670
6	(150)	85	180	317	476	677	846	995	1058
8	(200)	174	371	654	981	1395	1744	2049	2180
10	(250)	300	638	1125	1688	2401	3001	3526	3751
12	(300)	440	936	1651	2477	3523	4403	5174	5504
14	(350)	523	1110	1959	2939	4180	5225	6139	6531
16	(400)	659	1401	2473	3709	5276	6594	7748	8243
18	(450)	886	1883	3323	4985	7089	8862	10412	11077
20	(500)	1066	2266	3998	5998	8530	10662	12528	13328
24	(600)	1554	3302	5828	8741	12432	15540	18260	19425
30	(750)	2752	5848	10320	15480	22016	27520	32336	34400
36	(900)	3963	8421	14861	22291	31703	39629	46564	49536

SERIES 5300 CLASS 300

VALVE SIZE		DISC ANGLE, DEGREES OPEN							
in.	(mm)	20	30	40	50	60	70	80	90
2 1/2	(65)	8	17	31	46	66	82	97	103
3	(80)	14	31	54	81	115	144	169	180
4	(100)	31	66	117	176	250	312	367	400
5	(125)	54	114	201	302	429	536	630	670
6	(150)	85	180	317	476	677	846	995	1058
8	(200)	174	371	654	981	1395	1744	2049	2180
10	(250)	268	570	1005	1508	2145	2681	3150	3351
12	(300)	399	849	1498	2247	3196	3995	4693	4993
14	(350)	428	910	1606	2409	3426	4282	5032	5353
16	(400)	609	1295	2285	3428	4876	6094	7161	7618
18	(450)	848	1730	2983	4504	6303	7594	8379	8855
20	(500)	906	1926	3378	5098	7250	9062	10648	11328
24	(600)	1290	2629	4534	6847	9580	11542	12738	15520

SERIES 5600 CLASS 600

VALVE SIZE		DISC ANGLE, DEGREES OPEN							
in.	(mm)	20	30	40	50	60	70	80	90
3	(80)	14	31	54	81	115	144	169	180
4	(100)	23	50	88	132	188	234	275	293
6	(150)	67	141	249	374	532	665	781	831
8	(200)	155	330	583	874	1243	1554	1826	1942
10	(250)	241	512	904	1356	1929	2411	2833	3014
12	(300)	336	714	1260	1890	2688	3360	3948	4200

DYNACENTRIC HIGH PERFORMANCE BUTTERFLY VALVES TORQUE VALUES

The Torque Values shown in these tables are net required operating torques for actuator sizing. An appropriate safety factor is included for normal wet operating torque.

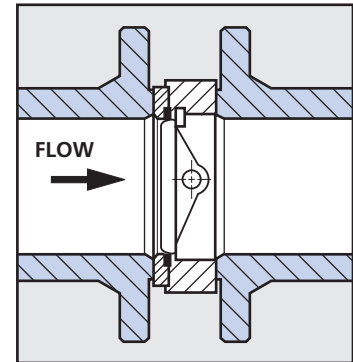

50 SEATS UPSTREAM - VALVE TORQUE (in. lb.)

Size in. (mm)	2 1/2 (65)	3 (80)	4 (100)	5 (125)	6 (150)	8 (200)	10 (250)	12 (300)	14 (350)	16 (400)	18 (450)	20 (500)	24 (600)	30 (750)	36 (900)
0-50 psi	111	155	348	503	728	1125	2154	3291	4277	6334	8129	11685	15770	23040	36030
100 psi	136	190	395	583	860	1290	2430	3790	5050	7469	9533	13556	18540	26980	44450
200 psi	179	250	490	737	1110	1600	2990	4790	6610	9740	12340	17297	24080	35390	61520
285 psi	214	300	570	871	1330	1900	3460	5640	7930	11670	14276	20477	28790	43200	75000
300 psi	225	315	590	899	1370	1950	3550	5790	8160	12010	15147	21038	29620	-	-
400 psi	271	380	680	1053	1630	2280	4100	6800	9720	14281	17955	24780	35160	-	-
500 psi	318	445	780	1205	1880	2610	4660	7800	11270	16551	20762	28521	40700	-	-
600 psi	364	510	875	1368	2140	2940	5220	8800	12820	18821	23570	32262	46240	-	-
700 psi	411	575	970	1526	2400	3270	5780	9800	14380	21092	26377	36003	51780	-	-
740 psi	429	600	1020	1597	2500	3400	6000	10200	15000	22000	27500	37500	54000	-	-

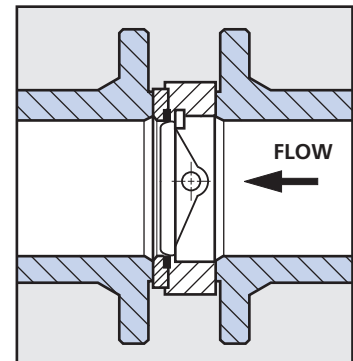

50 SEATS DOWNSTREAM - VALVE TORQUE (in. lb.)

Size in. (mm)	2 1/2 (65)	3 (80)	4 (100)	5 (125)	6 (150)	8 (200)	10 (250)	12 (300)	14 (350)	16 (400)	18 (450)	20 (500)	24 (600)	30 (750)	36 (900)
0-50 psi	111	155	348	503	728	1125	2154	3291	4277	6334	8129	11685	15770	23040	36030
100 psi	143	200	419	618	911	1364	2563	4013	5380	7947	10131	14371	19714	30000	46580
200 psi	208	291	561	846	1276	1841	3381	5458	7586	11174	14134	19743	27603	43820	70000
285 psi	263	368	681	1040	1587	2247	4077	6686	9462	13917	17536	24309	34308	55980	90000
300 psi	272	381	702	1074	1642	2319	4200	6903	9793	14401	18137	25114	35491	-	-
400 psi	337	472	844	1302	2007	2796	5018	8348	11999	17628	22140	30486	43379	-	-
500 psi	402	563	986	1530	2373	3274	5836	9793	14205	20855	26143	35858	51268	-	-
600 psi	466	653	1128	1757	2738	3751	6654	11237	16411	24082	30146	41230	59156	-	-
700 psi	531	744	1269	1985	3104	4229	7473	12682	18618	27309	34149	46601	67045	-	-
740 psi	557	780	1326	2076	3250	4420	7800	13260	19500	28800	35750	48750	70200	-	-

For severe service, additional safety factor should be added:

Dry gas or slurry..... 1.25 Low Temperature.....1.20
Emergency Shutdown..... 1.60

DYNACENTRIC HIGH PERFORMANCE BUTTERFLY VALVES TORQUE VALUES

The Torque Values shown in these tables are net required operating torques for actuator sizing. An appropriate safety factor is included for normal wet operating torque.

F0/M0 SEATS UPSTREAM - VALVE TORQUE (in. lb.)

Size in. (mm)	2 1/2 (65)	3 (80)	4 (100)	5 (125)	6 (150)	8 (200)	10 (250)	12 (300)	14 (350)	16 (400)	18 (450)	20 (500)	24 (600)	30 (750)	36 (900)
0-50 psi	238	333	609	920	1389	2710	4422	6547	7728	9709	13116	18395	25623	36600	53610
100 psi	261	366	694	1046	1578	3050	5043	7595	8956	11218	15432	21289	29746	42805	62660
200 psi	308	431	863	1300	1957	3729	6286	9689	11412	14235	20063	27079	37991	55130	78620
285 psi	348	487	1006	1514	2278	4307	7343	11470	13500	16800	24000	32000	45000	64980	90000
300 psi	355	497	1032	1552	2335	4409	7531	11784	13868	17253	24695	32868	46237		
400 psi	401	562	1201	1805	2714	5089	8773	13878	16325	20270	29326	38658	54482		
500 psi	449	628	1370	2058	3092	5769	10016	15973	18781	23288	33958	44447	62728		
600 psi	495	693	1539	2311	3470	6448	11259	18068	21237	26305	38589	50237	70974		
700 psi	542	759	1707	2563	3849	7128	12503	20162	23693	29323	43221	56026	79219		
740 psi	561	785	1775	2665	4000	7400	13000	21000	24675	30530	48074	58342	82518		
800 psi	589	824	1876	2816	4227	7808	13746	22257							
900 psi	636	890	2045	3069	4605	8488	14989	24351							
1000 psi	682	955	2214	3322	4984	9167	16232	26446							
1100 psi	729	1021	2383	3575	5382	9847	17476	28541							
1200 psi	776	1086	2552	3828	5741	10527	18719	30635							
1300 psi	823	1152	2721	4080	6119	11206	19962	32730							
1400 psi	870	1218	2890	4333	6497	11886	21205	34824							
1480 psi	907	1270	3025	4535	6800	12430	22200	36500							

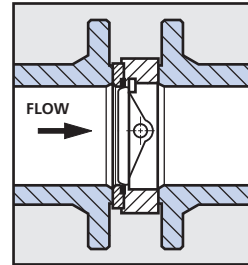

F0/M0 SEATS DOWNSTREAM - VALVE TORQUE (in. lb.)

Size in. (mm)	2 1/2 (65)	3 (80)	4 (100)	5 (125)	6 (150)	8 (200)	10 (250)	12 (300)	14 (350)	16 (400)	18 (450)	20 (500)	24 (600)	30 (750)	36 (900)
0-50 psi	238	333	609	920	1389	2710	4422	6547	7728	9709	13116	18395	25623	36600	53610
100 psi	274	383	733	1105	1665	3211	5326	8051	9314	11660	16085	22135	30942	45080	66020
200 psi	344	482	979	1474	2218	4212	7134	11059	12485	15562	22023	29616	41579	61750	91710
285 psi	405	567	1188	1787	2687	5063	8672	13615	15181	18880	27070	35974	50621	75000	115000
300 psi	416	582	1225	1842	2770	5214	8943	14066	15656	19465	27961	37096	52216		
400 psi	487	682	1471	2211	3322	6215	10751	17074	18828	23367	33899	44577	62854		
500 psi	558	781	1717	2579	3875	7216	12560	20082	21999	27270	39837	52057	73491		
600 psi	629	881	1963	2948	4427	8218	14368	23089	25171	31172	45775	59538	84129		
700 psi	701	981	2209	3316	4979	9219	16177	26097	28342	35075	51713	67018	94766		
740 psi	729	1021	2308	3464	5200	9620	16900	27300	29611	36636	54088	70011	99021		
800 psi	771	1080	2455	3685	5531	10221	17985	29105							
900 psi	843	1180	2701	4054	6084	11222	19794	32112							
1000 psi	914	1280	2947	4422	6636	12224	21602	35120							
1100 psi	985	1379	3193	4791	7188	13225	23410	38127							
1200 psi	1056	1479	3440	5160	7741	14227	25219	41135							
1300 psi	1128	1579	3686	5529	8293	15228	27027	44143							
1400 psi	1199	1678	3932	5897	8845	16230	28836	47150							
1480 psi	1256	1758	4129	6192	9287	17031	30283	49557							

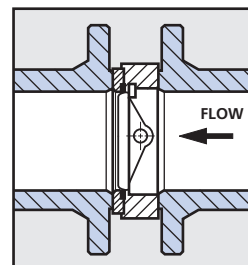

For Severe service, additional safety factor should be added:

Dry gas or slurry.....	1.25	Low Temperature.....	1.20
Emergency Shutdown.....	1.60	High Temperature 600°F - 700°F (316°C - 371°C).....	1.30
		Extended High Temp. 750°F - 1000°F (399°C - 538°C).....	1.50

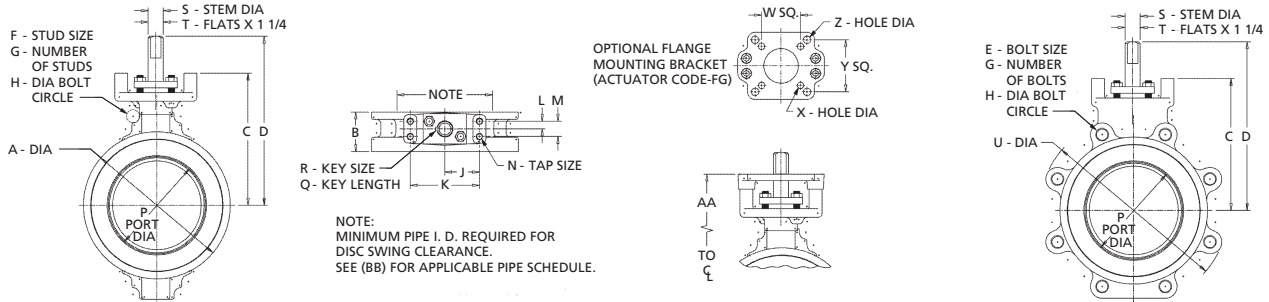
DYNACENTRIC HIGH PERFORMANCE BUTTERFLY VALVES - DIMENSIONAL DATA

SERIES B5100, CLASS 150, 285 psi CWP*

in. (mm)	A	B	C	D	E	F	G**	H	J	K	L	M	N	P
2 1/2 (65)	-	1.87 (48)	5.81 (148)	7.94 (202)	5/8-11	-	4	5.50 (140)	2.00 (51)	4.00 (102)	0.44 (11)	0.88 (22)	3/8-16	2.09 (53)
3 (80)	5.00 (127)	2.00 (51)	5.50 (140)	7.63 (194)	5/8-11	5/8	4	6.00 (152)	2.00 (51)	4.00 (102)	0.44 (11)	0.88 (22)	3/8-16	2.62 (53)
4 (100)	6.19 (157)	2.12 (54)	6.38 (162)	8.50 (216)	5/8-11	5/8	8	7.50 (191)	2.00 (51)	4.00 (102)	0.44 (11)	0.88 (22)	3/8-16	3.63 (92)
5 (125)	-	2.25 (57)	7.50 (191)	9.63 (245)	3/4-10	-	8	8.50 (216)	2.00 (51)	4.00 (102)	0.44 (11)	0.88 (22)	3/8-16	4.50 (114)
6 (150)	8.50 (216)	2.28 (58)	7.63 (194)	9.75 (248)	3/4-10	3/4	8	9.50 (241)	2.00 (51)	4.00 (102)	0.44 (11)	0.88 (22)	3/8-16	5.62 (143)
8 (200)	10.62 (270)	2.50 (64)	8.88 (226)	11.58 (294)	3/4-10	3/4	8	11.75 (298)	2.13 (54)	4.25 (108)	0.63 (16)	1.25 (32)	3/8-16	7.61 (193)
10 (250)	12.75 (324)	2.81 (71)	9.88 (251)	12.62 (321)	7/8-9	7/8	12	14.25 (362)	2.13 (54)	4.25 (108)	0.63 (16)	1.25 (32)	3/8-16	9.50 (241)
12 (300)	15.00 (381)	3.19 (81)	11.25 (286)	14.81 (376)	7/8-9	7/8	12	17.00 (432)	2.75 (70)	5.50 (140)	0.81 (21)	1.62 (41)	1/2-13	11.50 (292)
14 (350)	16.25 (413)	3.62 (92)	10.75 (274)	15.58 (396)	1-8	1	12	18.75 (476)	3.44 (87)	6.88 (175)	0.88 (22)	1.75 (44)	1/2-13	12.46 (316)
16 (400)	18.50 (470)	4.00 (102)	12.28 (312)	17.83 (453)	1-8	1	16	21.25 (540)	3.44 (87)	6.88 (175)	0.88 (22)	1.75 (44)	1/2-13	14.30 (363)
18 (450)	21.00 (533)	4.50 (114)	14.50 (368)	20.84 (529)	1 1/8-8	1 1/8	16	22.75 (578)	4.75 (121)	9.50 (241)	1.00 (25)	2.00 (51)	0.69 thru	16.26 (413)
20 (500)	23.00 (584)	5.00 (127)	15.81 (402)	22.44 (570)	1 1/8-8	1 1/8	20	25.00 (635)	4.75 (121)	9.50 (241)	1.00 (25)	2.00 (51)	0.69 thru	18.08 (459)
24 (600)	27.25 (692)	6.06 (154)	17.75 (451)	24.75 (629)	1 1/4-8	1 1/4	20	29.50 (749)	4.75 (121)	9.50 (241)	1.00 (25)	2.00 (51)	0.69 thru	21.45 (545)
36 (900)	-	8.12 (206)	25.00 (635)	33.38 (848)	1 1/2-8	-	32	42.75 (1086)	7.50	15.00 (381)	2.19 (56)	4.38 (111)	1-8	33.88 (861)

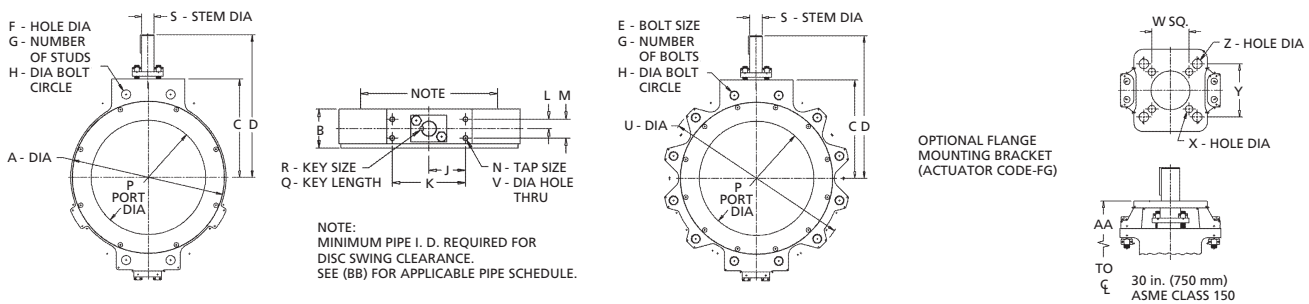
															Weight		
in. (mm)	Q	R	S	T	U	W	X	Y	Z	AA	BB	Lug Body lb. (kg)	Wafer Body lb. (kg)				
2 1/2 (65)	-	-	0.500 (13)	0.375 (10)	6.75 (171)	2.25 (57)	0.34 (9)	3.00 (76)	0.41 (10)	6.69 (170)	Sch 160	13 (6)	-	-			
3 (80)	-	-	0.625 (16)	0.437 (11)	7.25 (184)	2.25 (57)	0.34 (9)	3.00 (76)	0.41 (10)	6.38 (162)	Sch 160	15 (7)	11 (5)	-			
4 (100)	-	-	0.625 (16)	0.437 (11)	8.75 (222)	2.25 (57)	0.34 (9)	3.00 (76)	0.41 (10)	7.26 (184)	Sch 80	21 (10)	15 (7)	-			
5 (125)	-	-	0.875 (22)	0.625 (16)	10.00 (254)	2.25 (57)	0.34 (9)	3.00 (76)	0.41 (10)	8.38 (213)	Sch 80	33 (15)	-	-			
6 (150)	-	-	0.875 (22)	0.625 (16)	10.86 (276)	2.25 (57)	0.34 (9)	3.00 (76)	0.41 (10)	8.50 (216)	Sch 40	38 (17)	28 (13)	-			
8 (200)	1.56 (40)	0.250 (6.35) Sq.	1.125 (29)	-	13.25 (337)	-	-	3.50 (89)	0.56 (14)	10.00 (254)	Sch 40	53 (24)	44 (20)	-			
10 (250)	1.56 (40)	0.250 (6.35) Sq.	1.125 (29)	-	16.00 (406)	-	-	3.50 (89)	0.56 (14)	11.00 (279)	Sch 40	88 (40)	63 (29)	-			
12 (300)	2.00 (51)	0.312 (7.92) Sq.	1.375 (35)	-	18.75 (476)	3.50 (89)	0.56 (14)	5.31 (135)	0.69 (18)	12.75 (324)	Sch 40	132 (60)	102 (46)	-			
14 (350)	2.00 (51)	0.312 (7.92) Sq.	1.375 (35)	-	20.75 (527)	3.50 (89)	0.57 (14)	4.78 (121) Sq.	0.81 (21)	13.50 (343)	Sch 40	215 (98)	130 (59)	-			
16 (400)	2.75 (70)	0.375 (9.53) Sq.	1.750 (44)	-	23.25 (591)	4.06 (103)	0.81 (21)	5.31 (135) Sq.	0.69 (18)	15.03 (382)	Sch 40	280 (127)	185 (84)	-			
18 (450)	3.00 (76)	0.500 (12.70) Sq.	2.000 (51)	-	25.00 (635)	4.78 (121)	0.81 (21)	2.88 x 6.94 (73 x 176)	0.94 (24)	17.50 (445)	Sch 40	365 (166)	260 (118)	-			
20 (500)	3.00 (76)	0.500 (12.70) Sq.	2.000 (51)	-	27.25 (692)	4.78 (121)	0.81 (21)	2.88 x 6.94 (73 x 176)	0.94 (24)	18.81 (478)	Sch 40	477 (216)	350 (159)	-			
24 (600)	3.75 (95)	0.625 (15.88) Sq.	2.500 (64)	-	32.00 (813)	4.78 (121)	0.81 (21)	2.88 x 6.94 (73 x 176)	0.94 (24)	20.75 (527)	Sch 40	670 (304)	540 (245)	-			
36 (900)	6.50 (165)	0.875 (22.23) Sq.	3.750 (95)	-	45.75 (1162)	10.25 (260)	0.81 (21)	-	-	29.00 (737)	Sch 40	2185 (991)	-	-			

SERIES A5100, CLASS 150, 285 psi CWP*

in. (mm)	A	B	C	D	E	F	G**	H	J	K	L	M	N	P
30 (750)	34.50 (876)	7.63 (194)	22.88 (581)	30.94 (786)	1 1/4-8	1 1/4-8	28	36.00 (914)	6.00 (152)	12.00 (305)	1.50 (38)	3.00 (76)	3/4-10	27.90 (709)

															Weight		
in. (mm)	Q	R	S	U	Y	Z	AA	BB	Lug Body lb. (kg)	Wafer Body lb. (kg)							
30 (750)	4.00 (102)	0.875 (22.23) Sq.	3.500 (89)	38.75 (984)	3.92 x 9.47 (100 x 241)	0.81 (21)	26.88 (683)	Sch XH	1800 (816)	1300 (590)							

* Pressure ratings are in accordance with ASME B16.34 for group 1.1 carbon steel valves. Pressure ratings will vary with different body materials.
 ** Installation Manual is available with complete flange bolt / stud information.

DYNACENTRIC HIGH PERFORMANCE BUTTERFLY VALVES

DIMENSIONAL DATA

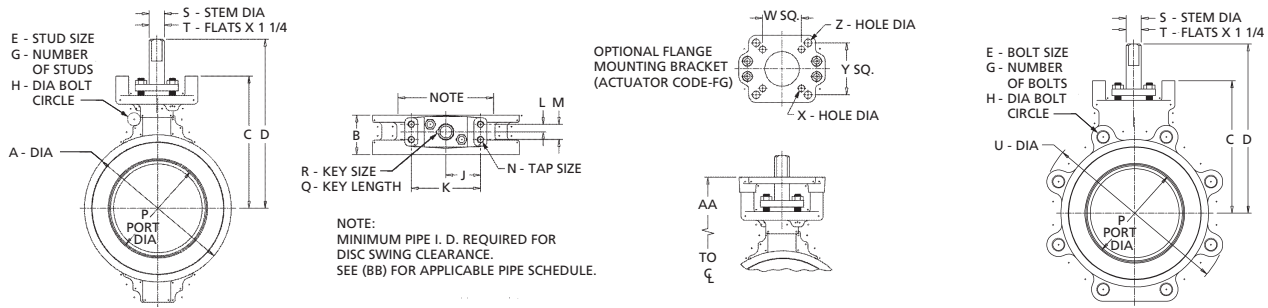

SERIES B5300, CLASS 300, 740 psi CWP*

in. (mm)	A	B	C	D	E	F	G**	H	J	K	L	M	N	P
2 1/2 (65)	4.13 (105)	1.87 (48)	5.81 (148)	7.94 (202)	3/4-10	3/4	8	5.58 (142)	2.00 (51)	4.00 (102)	0.44 (11)	0.88 (22)	3/8-16	2.09 (53)
3 (80)	5.00 (127)	2.00 (51)	5.50 (140)	7.63 (194)	3/4-10	3/4	8	6.63 (168)	2.00 (51)	4.00 (102)	0.44 (11)	0.88 (22)	3/8-16	2.62 (53)
4 (100)	6.19 (157)	2.12 (54)	6.38 (162)	8.50 (216)	3/4-10	3/4	8	7.88 (200)	2.00 (51)	4.00 (102)	0.44 (11)	0.88 (22)	3/8-16	3.63 (92)
5 (125)	7.31 (186)	2.25 (57)	7.50 (191)	9.63 (245)	3/4-10	3/4	8	9.25 (235)	2.00 (51)	4.00 (102)	0.44 (11)	0.88 (22)	3/8-16	4.50 (114)
6 (150)	8.50 (216)	2.28 (58)	7.63 (194)	9.75 (248)	3/4-10	3/4	12	10.63 (270)	2.00 (51)	4.00 (102)	0.44 (11)	0.88 (22)	3/8-16	5.62 (143)
8 (200)	10.62 (270)	2.88 (73)	8.88 (226)	11.58 (294)	7/8-9	7/8	12	13.00 (330)	2.13 (54)	4.25 (108)	0.63 (16)	1.25 (32)	3/8-16	7.61 (193)
10 (250)	12.75 (324)	3.25 (83)	10.88 (276)	14.41 (366)	1-8	1	16	15.25 (387)	2.75 (70)	5.50 (140)	0.81 (21)	1.62 (41)	1/2-13	9.50 (241)
12 (300)	15.00 (381)	3.62 (92)	12.25 (311)	16.48 (419)	1 1/8-8	1 1/8	16	17.75 (451)	2.75 (70)	5.50 (140)	0.81 (21)	1.62 (41)	1/2-13	11.50 (292)
14 (350)	16.25 (413)	4.62 (117)	13.62 (346)	19.98 (507)	1 1/8-8	1 1/8	20	20.25 (514)	4.75 (121)	9.50 (241)	1.00 (25)	2.00 (51)	0.69 thru	12.50 (318)
16 (400)	18.50 (470)	5.25 (133)	14.62 (371)	21.00 (533)	1 1/4-8	1 1/4	20	22.50 (572)	4.75 (121)	9.50 (241)	1.00 (25)	2.00 (51)	0.69 thru	14.37 (365)
18 (450)	21.00 (533)	5.88 (149)	16.16 (410)	23.16 (588)	1 1/4-8	1 1/4	24	24.75 (629)	4.75 (121)	9.50 (241)	1.00 (25)	2.00 (51)	0.69 thru	16.25 (413)
20 (500)	23.00 (584)	6.25 (159)	17.14 (435)	24.15 (613)	1 1/4-8	1 1/4	24	27.00 (686)	4.75 (121)	9.50 (241)	1.00 (25)	2.00 (51)	0.69 thru	18.03 (458)
24 (600)	27.25 (692)	7.25 (184)	19.62 (498)	27.69 (703)	1 1/2-8	1 1/2	24	32.00 (813)	6.00 (152)	12.00 (305)	1.50 (38)	3.00 (76)	3/4-10	21.40 (544)

Weight

in. (mm)	Q	R	S	T	U	W	X	Y	Z	AA	BB	Weight	
												Lug Body lb. (kg)	Wafer Body lb. (kg)
2 1/2 (65)	-	-	0.500 (13)	0.375 (10)	7.38 (187)	2.25 (57)	0.34 (9)	3.00 (76)	0.41 (10)	6.69 (170)	Sch 160	17 (8)	-
3 (80)	-	-	0.625 (16)	0.437 (11)	8.12 (206)	2.25 (57)	0.34 (9)	3.00 (76)	0.41 (10)	6.38 (162)	Sch 160	20 (9)	11 (5)
4 (100)	-	-	0.625 (16)	0.437 (11)	9.38 (238)	2.25 (57)	0.34 (9)	3.00 (76)	0.41 (10)	7.26 (184)	Sch 80	24 (11)	15 (7)
5 (125)	-	-	0.875 (22)	0.625 (16)	10.75 (273)	2.25 (57)	0.34 (9)	3.00 (76)	0.41 (10)	8.38 (213)	Sch 80	35 (16)	23 (10)
6 (150)	-	-	0.875 (22)	0.625 (16)	12.12 (308)	2.25 (57)	0.34 (9)	3.00 (76)	0.41 (10)	8.50 (216)	Sch 40	47 (21)	28 (13)
8 (200)	1.56 (40)	0.250 (6.35) Sq.	1.125 (29)	-	14.75 (375)	-	-	3.50 (89)	0.56 (14)	10.00 (254)	Sch 40	75 (34)	46 (21)
10 (250)	2.00 (51)	0.312 (7.92) Sq.	1.375 (35)	-	17.25 (438)	3.50 (89)	0.56 (14)	5.31 (135)	0.69 (18)	12.38 (314)	Sch 40	132 (60)	87 (39)
12 (300)	2.75 (70)	0.375 (9.53) Sq.	1.750 (44)	-	20.00 (508)	3.50 (89)	0.56 (14)	5.31 (135)	0.69 (18)	13.75 (349)	Sch 40	197 (89)	135 (61)
14 (350)	3.00 (76)	0.500 (12.70) Sq.	2.000 (51)	-	22.50 (572)	4.78 (121)	0.81 (21)	2.88 x 6.94	0.94 (24)	16.62 (422)	Sch 80	390 (177)	235 (107)
16 (400)	3.00 (76)	0.500 (12.70) Sq.	2.000 (51)	-	25.00 (635)	4.78 (121)	0.81 (21)	2.88 x 6.94	0.94 (24)	17.62 (448)	Sch 80	495 (225)	310 (141)
18 (450)	3.75 (95)	0.625 (15.88) Sq.	2.500 (64)	-	27.25 (692)	4.78 (121)	0.81 (21)	2.88 x 6.94	0.94 (24)	19.16 (487)	Sch 80	675 (306)	430 (195)
20 (500)	3.75 (95)	0.625 (15.88) Sq.	2.500 (64)	-	29.50 (749)	4.78 (121)	0.81 (21)	2.88 x 6.94	0.94 (24)	20.14 (512)	Sch 80	775 (352)	480 (218)
24 (600)	3.62 (92)	0.625 x 0.875	3.500 (89)	-	35.00 (889)	-	-	3.92 x 9.47	0.81 (21)	23.62 (600)	Sch 80	1325 (601)	815 (370)

* Pressure ratings are in accordance with ASME B16.34 for group 1.1 carbon steel valves. Pressure ratings will vary with different body materials.

** Installation Manual is available with complete flange bolt / stud information.

DYNACENTRIC HIGH PERFORMANCE BUTTERFLY VALVES

DIMENSIONAL DATA

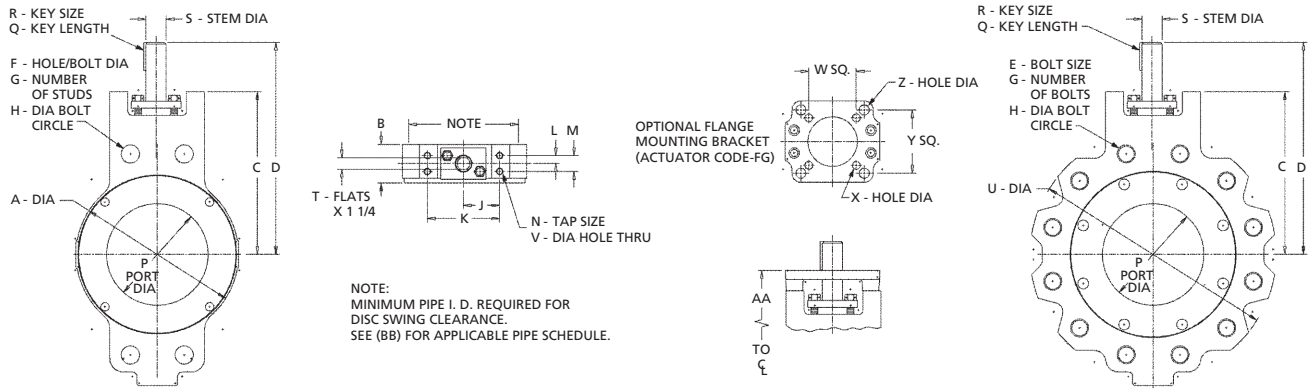

SERIES A5600, CLASS 600, 1480 psi CWP*

in. (mm)	A	B	C	D	E	F	G**	H	J	K	L	M	N	P
3 (80)	5.38 (137)	1.93 (49)	5.50 (140)	7.63 (194)	3/4-10	3/4	8	6.63 (168)	2.00 (51)	4.00 (102)	0.44 (11)	0.88 (22)	3/8-16	2.62 (67)
4 (100)	6.88 (175)	2.37 (60)	6.75 (171)	8.88 (226)	7/8-9	7/8	8	8.50 (216)	2.00 (51)	4.00 (102)	0.44 (11)	0.88 (22)	3/8-16	3.63 (92)
6 (150)	9.00 (229)	2.91 (74)	9.00 (229)	11.68 (297)	1-8	1	12	11.50 (292)	2.13 (54)	4.25 (108)	0.63 (16)	1.25 (32)	3/8-16	5.62 (143)
8 (200)	11.50 (292)	3.65 (93)	9.88 (251)	13.36 (339)	1 1/8-8	1 1/8	12	13.75 (349)	2.75 (70)	5.50 (140)	0.81 (21)	1.62 (41)	1/2-13	7.61 (193)
10 (250)	13.50 (343)	4.65 (118)	12.00 (305)	16.18 (411)	1 1/4-8	1 1/4-8	12	17.00 (432)	2.75 (70)	5.50 (140)	0.81 (21)	1.62 (41)	1/2-13	9.50 (241)
Weight														
													Lug Body	Wafer Body
in. (mm)	Q	R	S	T	U	W	X	Y	Z	AA	BB		lb. (kg)	lb. (kg)
3 (80)	-	-	0.625 (16)	0.437 (11)	8.12 (206)	2.25 (57)	0.34 (9)	3.00 (76)	0.41 (10)	6.38 (162)	Sch 160	25 (11)	11 (5)	
4 (100)	-	-	0.875 (22)	0.625 (16)	10.50 (267)	2.25 (57)	0.34 (9)	3.00 (76)	0.41 (10)	7.63 (194)	Sch 120	53 (24)	30 (14)	
6 (150)	1.56 (40)	0.250 (6.35)	Sq. 1.125 (29)	-	13.63 (346)	-	-	3.50 (89)	0.56 (14)	10.12 (257)	Sch 120	85 (39)	52 (24)	
8 (200)	2.00 (51)	0.312 (7.92)	Sq. 1.375 (35)	-	16.12 (409)	3.50 (89)	0.56 (14)	5.31 (135)	0.69 (18)	11.38 (289)	Sch 80	165 (75)	105 (48)	
10 (250)	2.75 (70)	0.375 (9.53)	Sq. 1.750 (44)	-	19.50 (495)	3.50 (89)	0.56 (14)	5.31 (135)	0.69 (18)	13.50 (343)	Sch 120	329 (149)	225 (102)	

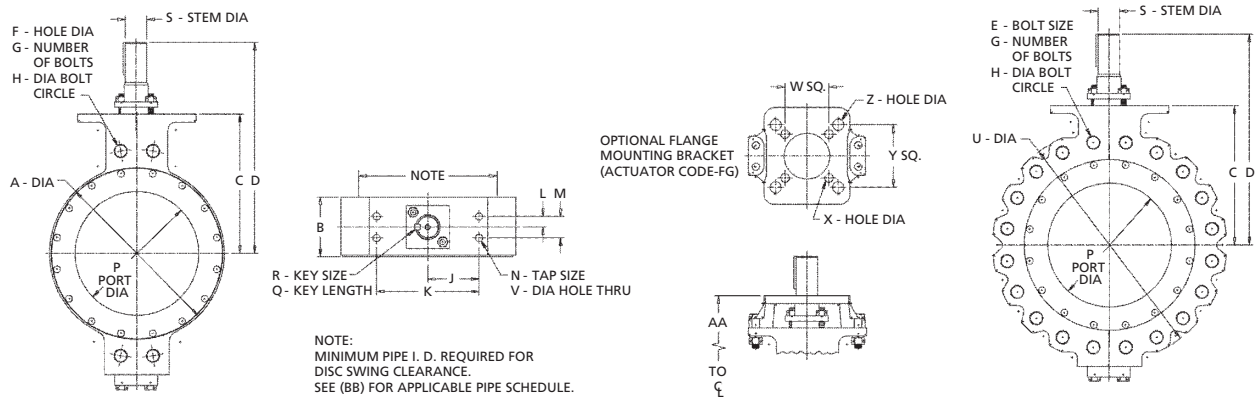

SERIES A5600, CLASS 600, 1480 psi CWP*

in. (mm)	A	B	C	D	E	F	G**	H	J	K	L	M	N	P
12 (300)	16.25 (413)	5.53 (140)	12.94 (329)	19.58 (497)	1 1/4-8	1 1/4-8	20	19.25 (489)	4.75 (121)	9.50 (241)	1.00 (25)	2.00 (51)	-	11.50 (292)
Weight														
													Lug Body	Wafer Body
in. (mm)	Q	R	S	U	V	W	X	Y	Z	AA	BB		lb. (kg)	lb. (kg)
12 (300)	3.00 (76)	0.500 (12.7)	Sq. 2.00 (51)	21.75 (552)	0.69 (18)	4.78 (121)	0.81 (21)	2.88 x 6.94	0.94 (24)	15.94 (405)	Sch 80	520 (236)	360 (163)	

* Pressure ratings are in accordance with ASME B16.34 for group 1.1 carbon steel valves. Pressure ratings will vary with different body materials.
 ** Installation Manual is available with complete flange bolt / stud information.

DYNACENTRIC HIGH PERFORMANCE BUTTERFLY VALVES MANUAL ACTUATORS

Worm Gear Actuators

Worm gear actuators are available as optional equipment, for DynaCentric High Performance Butterfly Valves sizes 2 1/2 in. through 8 in. (65 mm through 200 mm). All larger size valves require worm gear actuators or power actuation.

Handle operated valves, sizes 2 1/2 in. through 8 in. (65 mm through 200 mm), can be converted in the field to worm gear operation. No modification is required to accommodate the addition of the worm gear unit.

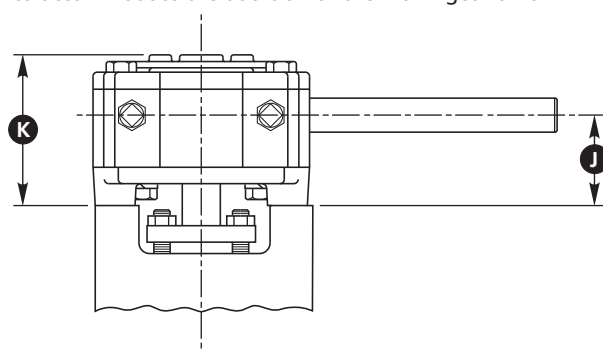
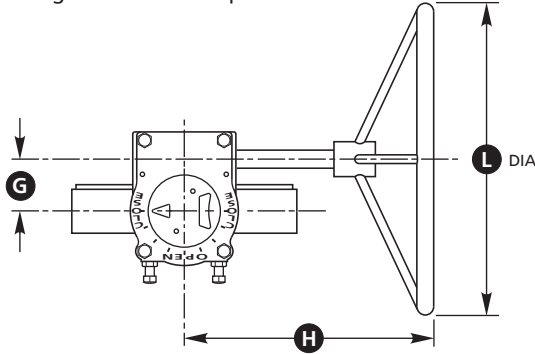

Valve Size in. (mm)	ASME Class	G	H	J	K	L Dia.	Weight lb. (kg)
2 1/2 (65)	150/300	1.64 (42)	7.25 (184)	1.75 (44)	3.13 (79)	8.00 (203)	11 (5)
3 (80)	150/300/600	1.75 (44)	7.25 (184)	1.98 (50)	3.45 (87)	8.00 (203)	15 (7)
4 (100)	150/300/600	1.75 (44)	7.25 (184)	1.98 (50)	3.45 (87)	8.00 (203)	15 (7)
5 (125)	150/300	1.75 (44)	7.25 (184)	1.98 (50)	3.45 (87)	8.00 (203)	15 (7)
6 (150)	150/300	1.75 (44)	7.25 (184)	1.98 (50)	3.45 (87)	8.00 (203)	15 (7)
6 (150)	600	2.51 (64)	10.28 (261)	2.49 (63)	4.04 (102)	12.00 (305)	23 (10)
8 (200)	150/300	2.51 (64)	10.28 (261)	2.49 (63)	4.04 (102)	12.00 (305)	23 (10)
8 (200)	600	3.00 (76)	14.02 (356)	3.00 (76)	4.68 (118)	18.00 (457)	39 (18)
10 (250)	150	2.51 (64)	10.28 (261)	2.49 (63)	4.04 (102)	12.00 (305)	23 (10)
10 (250)	300	3.00 (76)	14.02 (356)	3.73 (95)	4.68 (118)	18.00 (457)	39 (18)
10 (250)	600	3.63 (92)	16.38 (416)	3.73 (95)	6.01 (153)	24.00 (610)	49 (22)
12 (300)	150	3.00 (76)	14.02 (356)	3.00 (76)	4.68 (118)	18.00 (457)	39 (18)
12 (300)	300	3.63 (92)	16.38 (416)	3.73 (95)	6.01 (153)	24.00 (610)	49 (22)
12 (300)	600	3.63 (92)	18.95 (481)	5.23 (133)	7.14 (181)	30.00 (762)	51 (23)
14 (350)	150	3.00 (76)	14.02 (356)	4.25 (108)	5.93 (150)	18.00 (457)	39 (18)
14 (350)	300	4.63 (118)	18.95 (481)	5.25 (133)	7.83 (198)	30.00 (762)	51 (23)
16 (400)	150	3.63 (92)	16.38 (416)	4.98 (126)	7.26 (184)	24.00 (610)	49 (22)
16 (400)	300	4.63 (118)	18.95 (481)	5.25 (133)	7.83 (198)	30.00 (762)	51 (23)
18 (450)	150	3.63 (92)	18.95 (481)	5.23 (133)	7.14 (181)	30.00 (762)	51 (23)
18 (450)	300	4.63 (118)	19.90 (505)	5.25 (133)	7.83 (198)	30.00 (762)	106 (48)
20 (500)	150	4.63 (118)	18.95 (481)	5.25 (133)	7.14 (181)	30.00 (762)	51 (23)
20 (500)	300	4.63 (118)	18.95 (481)	5.25 (133)	7.83 (198)	30.00 (762)	51 (23)
24 (600)	150	4.63 (118)	19.90 (505)	5.25 (133)	7.83 (198)	30.00 (762)	106 (48)
24 (600)	300	7.30 (185)	20.56 (522)	9.19 (233)	10.57 (268)	30.00 (762)	160 (73)
30 (750)	150	7.30 (185)	20.56 (522)	9.19 (233)	10.57 (268)	30.00 (762)	160 (73)
36 (900)	150	5.93 (151)	20.56 (522)	9.00 (228)	10.57 (268)	30.00 (762)	163 (74)

HANDLE ACTUATORS

Valve Size in. (mm)	ASME Class	Handle Number	A	B	C	D	E	Weight lb. (kg)
2 1/2 (65)	150/300	H-06 12 (305)	6.69 (170)	7.94 (202)	4.5 (114)	5.56 (141)	5 (2.3)	
3 (80)	150/300/600	H-16 12 (305)	6.38 (162)	7.62 (194)	4.5 (114)	5.56 (141)	5 (2.3)	
4 (100)	150/300	H-16 12 (305)	7.25 (184)	8.50 (216)	4.5 (114)	5.56 (141)	5 (2.3)	
4 (100)	600	H-36 18 (457)	7.63 (194)	8.88 (226)	4.5 (114)	5.56 (141)	9 (4.1)	
5 (125)	150/300	H-36 18 (457)	8.37 (213)	9.62 (244)	4.5 (114)	5.56 (141)	9 (4.1)	
6 (150)	150/300	H-36 18 (457)	8.50 (216)	9.75 (248)	4.5 (114)	5.56 (141)	9 (4.1)	
6 (150)	600	H-46 18 (457)	10.13 (257)	11.75 (298)	4.5 (114)	5.56 (141)	9 (4.1)	
8 (200)	150	H-46 18 (457)	10.00 (254)	11.50 (292)	4.5 (114)	5.56 (141)	9 (4.1)	

CAUTION: Handle should only be used up to the following differential pressures:

2 1/2 in. valves to 450 psi	5 in. valves to 200 psi
3 in. valves to 400 psi	6 in. valves to 150 psi
4 in. valves to 300 psi	8 in. valves to 50 psi

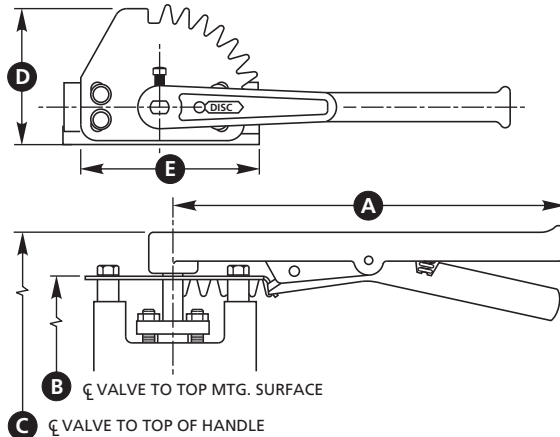

MATERIAL SELECTION GUIDE

A selection of body, disc, stem and seat/seal materials for DynaCentric High Performance Butterfly Valves are available. The following list is intended as a guide in the selection of materials for corrosive service.

No material can be expected to resist the corrosive action of all the many ladings found in modern industry. Experience has shown, however, that certain materials can perform satisfactorily within certain limits.

The physical properties of a material are affected differently by each corrosive medium.

Therefore, it sometimes becomes necessary to sacrifice value in another property.

As a result, the user must decide which property is of prime importance for his application.

Internal moving parts, in contact with the lading, should always carry an "A" rating.

Body materials with exposure to corrosive ladings can sometimes carry "B" rating because metal loss due to corrosive is not as critical.

The following information is designed for use by technically qualified individuals at there own discretion and risk. We strongly recommend that tests be run under actual operating conditions to obtain a material's performance ability in any one corrosive medium.

- Rating interpretation:** "A" - excellent;
 "B" - good (slightly attacked);
 "C" - fair (moderately attacked, probably unsuitable);
 "D" - not recommended.

LADINGS	MATERIALS OF CONSTRUCTION											
	BODY GROUPS			TRIM GROUPS					SEAL GROUPS			
	1	2	3	01*	02	03	04	05	S01	S02	F02	M01
Acetaldehyde	C	A	C	C	A	A	A	A	A	A	A	A
Acetate Solvents	A	A	A	A	A	A	A	A	A	A	A	A
Acetic Acid	D	A	D	D	B	A	A	B	A	A	A	A
Acetic Acid, crude	C	A	C	C	B	A	A	B	A	A	A	A
Acetic Anhydride	D	B	D	D	B	B	A	B	A	A	B	B
Acetone	A	A	A	A	A	A	A	A	A	A	A	A
Acetylene, dry only	A	A	A	A	A	A	A	A	A	A	A	A
Acrylonitrile	A	A	A	A	A	A	A	A	A	A	A	A
Alcohols-methyl, ethyl	B	A	B	B	A	A	A	A	A	A	A	A
Alcohols-amyl, butyl	B	A	B	B	B	A	A	B	A	A	A	A
Aluminum chloride, dry	B	A	B	B	D	A	A	D	A	A	A	A
Aluminum Sulfate, alums	C	A	C	C	C	A	A	C	A	A	A	A
Amines	A	A	A	A	A	A	A	A	A	A	A	A
Ammonia	A	A	A	A	A	A	B	A	A	A	A	A
Ammonia Solutions	B	A	B	B	A	A	B	A	A	A	A	A
Ammonium Bicarbonate	C	B	C	C	B	B	B	B	A	A	B	B
Ammonium Carbonate	B	B	B	B	B	B	B	B	A	A	B	B
Ammonium Chloride	D	C	D	D	D	C	B	D	A	A	C	C
Ammonium Hydroxide	C	B	C	C	B	B	D	B	A	C	C	B
Ammonium Monophosphate	D	B	D	D	B	B	C	B	A	A	B	B
Ammonium Nitrate	D	A	D	C	A	A	D	A	A	A	A	A
Ammonium Phosphate	D	B	D	D	B	B	C	B	A	A	B	B
Ammonium Sulfate	C	B	C	B	B	B	C	B	A	A	B	B
Amyl Acetate	C	B	C	B	B	B	B	B	A	A	B	B
Aniline	A	B	A	C	B	B	B	B	A	A	B	B
Aniline Dyes	C	A	C	C	A	A	A	A	A	A	A	A
Antimony Trichloride	D	D	D	D	D	D	B	D	A	A	D	D
Arsenic Acid	D	B	D	D	B	B	D	B	A	A	B	B
Asphalt, emulsion/liquid	A	A	A	A	A	A	A	A	A	A	A	A
Barium Carbonate	B	B	B	B	B	B	B	B	A	A	B	B
Barium Chloride	C	C	C	D	C	C	B	C	A	A	C	C
Barium Hydroxide	C	B	C	C	B	B	B	B	A	A	B	B
Barium Sulfate	B	B	B	C	B	B	A	B	A	A	B	B
Barium Sulfide	B	B	B	C	B	B	B	B	A	A	B	B
Beer	C	A	C	B	A	A	A	A	A	A	A	A
Beet Sugar Liquors	B	A	B	B	A	A	A	A	A	A	A	A

LADINGS	MATERIALS OF CONSTRUCTION											
	BODY GROUPS			TRIM GROUPS					SEAL GROUPS			
	1	2	3	01*	02	03	04	05	S01	S02	F02	M01
Benzene, Benzoil	B	A	B	B	A	A	A	A	A	A	A	A
Benzaldehyde	A	A	A	A	A	A	A	A	A	A	A	A
Benzoic Acid	D	B	D	D	B	B	B	B	A	A	B	B
Borax Liquors	C	B	C	C	B	B	A	B	A	A	B	B
Boric Acid	D	B	D	C	B	B	A	B	A	A	B	B
Brines	C	B	C	C	B	A	C	A	C	A	B	B
Bromine, dry	D	D	D	D	D	D	A	D	A	A	D	D
Bromine, wet	D	D	D	D	D	D	B	D	A	A	D	D
Butadiene	B	A	B	B	A	A	C	A	B	B	A	A
Butane	A	A	A	A	A	A	A	A	A	A	A	A
Butylene	A	A	A	A	A	A	A	A	A	A	A	A
Buttermilk	D	A	D	B	A	A	D	A	A	A	A	A
Butyric Acid	D	B	D	D	B	B	B	B	A	A	B	B
Calcium Bisulfide	D	B	D	D	B	B	B	B	A	A	B	B
Calcium Carbonate	D	B	D	B	A	B	B	A	A	A	B	B
Calcium Chloride	C	B	C	B	B	B	A	B	A	A	B	B
Calcium Hydroxide, 20%	B	B	B	C	B	B	A	B	A	A	B	B
Calcium Hypochlorite	D	C	D	D	C	C	C	C	A	A	C	C
Calcium Sulfate	C	B	C	C	B	B	B	B	A	A	B	B
Carbolic Acid	D	B	D	B	B	B	B	B	A	A	B	B
Carbon Bisulfide	B	-	B	B	B	-	A	B	B	A	A	-
Carbon Dioxide, dry	A	A	A	A	A	A	A	A	A	A	A	A
Carbonic Acid	D	B	D	C	B	B	A	B	A	A	B	B
Carbon Tetrachloride, dry	B	A	B	A	A	A	A	A	A	A	A	A
Carbon Tetrachloride, wet	D	B	D	B	B	B	B	B	A	A	B	B
Carbonated Water	B	A	B	B	A	A	A	A	A	A	A	A
China Wood Oil, Tung Oil	C	A	C	C	A	A	A	A	A	A	A	A
Chlorinated Solvents, dry	C	B	C	C	B	B	B	B	A	A	B	B
Chlorine Gas, dry	B	B	B	B	C	B	B	C	A	A	B	B
Chlorine, wet	D	D	D	D	D	C	D	C	D	A	A	D
Chloroacetic Acid	D	C	D	D	C	C	B	C	A	A	C	C
Chlorobenzene, dry	B	A	B	B	B	A	A	B	A	A	A	A
Chloroform, dry	B	A	B	B	A	A	A	A	A	A	A	A
Chlorosulphonic Acid, dry	B	B	B	B	B	B	B	A	B	A	B	B
Chlorosulphonic Acid, wet	D	D	D	D	D	D	C	D	A	A	A	A
Chrome Alum	B	A	B	B	A	A	B	A	A	A	A	A

Note: All ladings at ambient temperatures except as noted.
 * Size 14 in. (350 mm) and larger, Class 150/300 valves are available with CS trim.

MATERIAL SELECTION GUIDE (CONTINUED)

LADINGS	MATERIALS OF CONSTRUCTION											
	BODY GROUPS			TRIM GROUPS					SEAL GROUPS			
	1	2	3	01*	02	03	04	05	S01	S02	F02	M01
Chromic Acid	D	C	D	D	C	C	B	C	A	A	C	C
Citrus Juices	D	B	D	C	B	B	A	B	A	A	B	B
Coconut Oil	C	B	C	B	B	B	B	B	A	A	B	B
Coffee Extracts, hot	C	A	C	B	A	A	A	A	A	A	A	A
Coke Oven Gas	B	A	B	B	A	A	B	A	A	A	A	A
Cooking Oil	B	A	B	B	A	A	A	A	A	A	A	A
Copper Acetate, 10%	C	B	C	C	B	B	B	B	A	A	B	B
Copper Chloride	D	D	D	D	D	D	C	D	A	A	D	D
Copper Nitrate	D	B	D	D	B	B	C	B	A	A	B	B
Copper Sulfate	D	C	D	D	C	C	B	C	A	A	C	C
Corn Oil	C	B	C	B	B	B	B	B	A	A	B	B
Cottonseed Oil	C	B	C	B	B	B	B	B	A	A	B	B
Creosote Oil	B	B	B	B	B	B	A	B	A	A	B	B
Cresylic Acid	B	B	B	B	B	B	B	B	A	A	B	B
Crude Oil	B	A	B	A	A	A	A	A	A	A	A	A
Cutting Oils, water emul.	B	A	B	B	A	A	-	A	A	A	A	A
Cyclohexane	A	A	A	A	A	A	A	A	A	A	A	A
Diacetone Alcohol	A	A	A	A	A	A	A	A	A	A	A	A
Diesel Fuels	A	A	A	A	A	A	A	A	A	A	A	A
Diethylamine	A	A	A	A	A	A	A	A	A	A	A	A
Dowtherms	B	A	B	B	A	A	A	A	A	A	A	A
Drilling Mud	B	A	B	A	A	A	A	A	A	A	A	A
Drip Cocks, gas	B	A	B	B	A	A	A	A	A	A	A	A
Dry Cleaning Fluids	B	A	B	B	A	A	B	A	A	A	A	A
Drying Oil	C	B	C	C	B	B	B	B	A	A	B	B
Epsom Salt	C	B	C	C	B	B	B	B	A	A	B	B
Ethane	A	A	A	A	A	A	A	A	A	A	A	A
Ethers	B	A	B	B	A	A	B	A	A	A	A	A
Ethyl Diethyl Acetate	B	B	B	B	B	B	B	B	A	A	B	B
Ethylene, liquid or gas	A	A	A	A	A	A	A	A	A	A	A	A
Ethyl Acrylate	A	A	A	A	A	A	A	A	A	A	A	A
Ethyl Chloride, dry	B	A	B	B	A	A	B	A	A	A	A	A
Ethyl Chloride, wet	D	B	D	D	B	B	B	B	A	A	B	B
Ethylene Glycol	B	B	B	B	B	B	B	B	A	A	B	B
Ethylene Oxide	B	B	B	B	B	B	B	B	A	A	B	B
Fatty Acids	D	B	D	B	B	B	B	B	A	A	B	B
Ferric Chloride	D	D	D	D	D	D	C	D	A	A	D	D
Ferric Nitrate	D	C	D	D	C	C	C	C	A	A	C	C
Ferric Sulfate	D	B	D	D	B	B	B	B	A	A	B	B
Ferrous Chloride	D	D	D	D	D	D	C	D	A	A	D	D
Ferrous Sulfate	D	B	D	D	B	B	B	B	A	A	B	B
Ferrous Sulfate, saturated	C	A	C	C	A	A	A	A	A	A	A	A
Ferilizer Solutions	B	B	B	B	B	B	B	B	A	A	B	B
Fish Oils	B	A	B	B	A	A	A	A	A	A	A	A
Fluorine, dry	B	A	B	B	A	A	A	A	C	C	C	A
Fluorosilicic Acid	D	C	D	D	C	C	C	C	A	-	C	C
Food Fluids and Pastes	C	A	C	C	A	A	A	A	A	A	A	A
Formaldehyde, cold	A	A	A	A	A	A	A	A	A	A	A	A
Formaldehyde, hot	D	C	D	D	C	C	B	C	A	A	C	C
Formic Acid, cold	D	B	D	C	B	B	B	B	A	A	B	B
Formic Acid, hot	D	D	D	D	D	D	B	D	A	A	D	D
Freon, dry (12)	B	A	B	A	A	A	A	A	A	A	A	A
Fruit Juices	D	A	D	D	A	A	A	A	A	A	A	A
Fuel Oils	B	A	B	A	A	A	A	A	A	A	A	A
Furfural	A	B	A	A	B	B	A	B	A	A	B	B
Gallic Acid	D	B	D	D	B	B	B	B	A	A	B	B

LADINGS	MATERIALS OF CONSTRUCTION											
	BODY GROUPS			TRIM GROUPS					SEAL GROUPS			
	1	2	3	01*	02	03	04	05	S01	S02	F02	M01
Gas, manufactured	B	B	B	B	B	B	A	B	A	A	B	B
Gas, natural	B	A	B	B	A	A	A	A	A	A	A	A
Gas Odorizers	B	B	B	B	B	B	B	B	A	A	B	B
Gasoline	A	A	A	A	A	A	A	A	A	A	A	A
Gasoline, sour	B	A	B	B	A	A	A	A	A	A	A	A
Gelatin	D	A	D	D	A	A	A	A	A	A	A	A
Glucose	B	A	B	B	A	A	A	A	A	A	A	A
Glue	A	A	A	A	A	A	A	A	A	A	A	A
Glycerine, Glycerol	B	A	B	A	A	A	A	A	A	A	A	A
Glycols	B	B	B	B	B	B	B	B	A	A	B	B
Grease	A	A	A	A	A	A	B	A	A	A	A	A
Heptane	A	A	A	A	A	A	A	A	A	A	A	A
Hexane	A	A	A	A	A	A	A	A	A	A	A	A
Hexanol, tertiary	A	A	A	A	A	A	A	A	A	A	A	A
Hydraulic Oil	A	A	A	A	A	A	A	A	A	A	A	A
Hydrobromic Acid	D	D	D	D	D	D	C	D	A	A	D	D
Hydrochloric Acid, air free	D	D	D	D	D	D	C	D	A	A	D	D
Hydrocyanic Acid	D	B	D	D	B	B	B	B	A	-	-	B
Hydrofluoric Acid	D	D	D	D	D	D	A	D	A	C	D	D
Hydrogen gas, cold	B	A	B	B	A	A	B	A	A	A	A	A
Hydrogen Peroxide	D	B	D	D	B	B	A	B	A	A	B	B
Hydrogen Sulfide, dry	Consult Factory											
Hydrogen Sulfide, wet	Consult Factory											
Hydrofluorosilicic Acid	D	C	D	D	C	C	B	C	A	A	C	C
Hypo (sodium thiosulfate)	D	A	D	D	A	A	B	A	A	A	A	A
Hypochlorites, sodium	D	C	D	D	C	C	B	C	A	A	C	C
Illuminating gas	A	A	A	A	A	A	A	A	A	A	A	A
Ink	D	A	D	D	A	A	B	A	A	A	A	A
Iodine, wet	D	D	D	D	D	D	D	D	A	A	D	D
Iodoform, dry	B	B	B	B	B	B	B	B	A	A	B	B
Iso-octane	A	A	A	A	A	A	A	A	A	A	A	A
Isopropyl Alcohol	B	B	B	B	B	B	B	B	A	A	B	B
Isopropyl Ether	A	A	A	A	A	A	A	A	A	A	A	A
JP Fuels	A	A	A	A	A	A	A	A	A	A	A	A
Kerosene	B	A	B	A	A	A	A	A	A	A	A	A
Ketchup	D	A	D	D	A	A	B	A	A	A	A	A
Ketones	A	A	A	A	A	A	A	A	A	A	A	A
Lacquers and solvents	C	A	C	C	A	A	A	A	A	A	A	A
Lactic Acid, dilute cold	D	A	D	D	B	A	C	B	A	A	A	A
Lactic Acid, dilute hot	D	A	D	D	B	A	D	B	A	A	A	A
Lactic Acid, conc. cold	D	A	D	D	B	A	D	B	A	A	A	A
Lactic Acid, conc. hot	D	B	D	D	B	B	D	B	A	A	B	B
Lard Oil	C	A	C	B	A	A	B	A	A	A	A	A
Lead Acetate	D	B	D	D	B	B	B	B	A	A	B	B
Linoleic Acid	B	A	B	B	B	A	B	B	A	A	A	A
Linseed Oil	A	A	A	A	A	A	B	A	A	A	A	A
Liquefied Pet. Gas (LPG)	B	B	B	B	B	B	B	B	A	A	B	B
Lubricating Oil	A	A	A	A	A	A	B	A	A	A	A	A
Magnesium Bisulfate, 10%	C	A	C	C	A	A	B	A	A	-	-	A
Magnesium Chloride	C	D	C	C	D	D	B	D	A	A	D	D
Magnesium Hydroxide	B	A	B	B	A	A	A	A	A	A	A	A
Magnesium Hydroxide, hot	B	A	B	B	A	A	A	A	A	A	A	A
Magnesium Sulfate	B	B	B	B	B	B	B	B	A	A	B	B
Maleic Acid	B	C	B	D	C	C	B	C	A	A	C	C
Malic Acid	D	A	D	D	A	A	B	A	A	A	A	A
Mayonnaise	D	A	D	D	A	A	B	A	A	A	A	A

Note: All ladings at ambient temperatures except as noted.
 * Size 14 in. (350 mm) and larger, Class 150/300 valves are available with CS trim.

MATERIAL SELECTION GUIDE (CONTINUED)

LADINGS	MATERIALS OF CONSTRUCTION												
	BODY GROUPS			TRIM GROUPS					SEAL GROUPS				
	1	2	3	01*	02	03	04	05	S01	S02	F02	M01	
Mercuric Chloride	D	D	D	D	D	D	D	D	A	A	A	D	
Mercuric Cyanide, 10%	D	B	D	D	B	B	D	B	A	A	B	B	
Mercury	A	A	A	A	A	A	C	A	A	A	A	A	
Mercaptans	A	A	A	A	A	A	D	A	A	A	A	A	
Methane	A	A	A	A	A	A	A	A	A	A	A	A	
Methyl Acetate	A	A	A	A	A	A	A	A	A	A	A	A	
Methyl Acetone	A	A	A	A	A	A	A	A	A	A	A	A	
Methylamine	B	B	B	B	B	B	B	B	A	A	B	B	
Methyl Cellosolve	B	B	B	B	B	B	B	B	A	A	B	B	
Methyl Chloride, dry	B	A	B	B	A	A	A	A	A	A	A	A	
Methyl Ethyl Ketone	A	A	A	A	A	A	A	A	A	A	A	A	
Methyl Formate	B	B	B	B	B	B	B	B	A	A	B	B	
Methylene Chloride, dry	B	B	B	B	B	B	B	B	A	A	B	B	
Milk	D	A	D	B	A	A	A	A	A	A	A	A	
Mine Waters, acid	D	B	D	D	B	B	B	B	A	A	B	B	
Mineral Oil	B	A	B	A	A	A	A	A	A	A	A	A	
Mineral Spirits	B	B	B	B	B	B	B	B	A	A	B	B	
Mixed Acids, cold	C	A	C	C	A	A	B	A	A	A	A	A	
Molasses	A	A	A	A	A	A	A	A	A	A	A	A	
Muriatic Acid	D	D	D	D	D	D	B	D	A	A	D	D	
Mustard	B	A	B	B	A	A	A	A	A	A	A	A	
Naphtha	B	A	B	B	A	A	B	A	A	A	A	A	
Naphthalene	A	A	A	A	A	A	B	A	A	A	A	A	
Nickel Ammonium Sulfate, 20%	D	A	D	D	A	A	B	A	A	A	A	A	
Nickel Chloride	D	B	D	D	B	B	B	B	A	A	B	B	
Nickel Nitrate, 30%	D	B	D	D	B	B	B	B	A	A	B	B	
Nickel Sulfate	D	C	D	D	C	C	B	C	A	A	C	C	
Nicotinic Acid	B	A	B	B	A	A	A	A	A	A	-	A	
Nitric Acid, 10-80%	D	A	D	D	A	A	D	A	A	A	A	A	
Nitric Acid, 100%	A	A	A	C	C	A	D	C	A	A	A	A	
Nitrobenzene	B	B	B	B	B	B	B	B	A	A	B	B	
Nitrogen	A	A	A	A	A	A	A	A	A	A	A	A	
Nitrous Acid, 10%	D	B	D	D	B	B	D	B	A	A	B	B	
Nitrous Gases	B	A	B	B	A	A	D	A	A	A	A	A	
Nitrous Oxide	A	B	A	A	B	D	B	A	A	A	B	B	
Oils, petroleum, refined	A	A	A	A	A	A	A	A	A	A	A	A	
Oil-water Mixtures	B	A	B	A	A	A	-	A	A	A	A	A	
Oleic Acid	B	A	B	B	B	A	B	B	A	A	A	A	
Oleum	B	B	B	B	B	B	D	B	A	A	B	B	
Olive Oil	B	A	B	B	A	A	A	A	A	A	A	A	
Oxalic Acid	D	D	D	D	D	D	B	D	A	A	D	D	
Oxygen	B	A	B	A	A	A	A	A	A	A	A	A	
Ozone, wet	C	A	C	C	A	A	A	A	A	A	A	A	
Ozone, dry	A	A	A	A	A	A	A	A	A	A	A	A	
Paints and solvents	A	A	A	A	A	A	A	A	A	A	A	A	
Palmitic Acid	C	A	C	C	B	A	B	B	A	A	A	A	
Palm Oil	C	B	C	C	B	B	A	B	A	A	B	B	
Paraffin	B	A	B	A	A	A	A	A	A	A	A	A	
Paraformaldehyde	B	B	B	B	B	B	B	B	A	A	B	B	
Pentane	B	A	B	A	A	B	A	A	A	A	A	A	
Perchloroethylene, dry	B	B	B	B	B	B	A	B	A	A	B	B	
Petrolatum	C	B	C	C	B	B	A	B	A	A	B	B	
Phenol	B	A	B	B	A	A	A	A	A	A	A	A	
Phosphoric Acid, 10% cold	D	B	D	D	B	B	B	B	A	A	B	B	
Phosphoric Acid, 10% hot	D	D	D	D	D	D	C	D	A	A	D	D	
Phosphoric Acid, 50% cold	D	B	D	D	B	B	C	B	A	A	B	B	

LADINGS	MATERIALS OF CONSTRUCTION												
	BODY GROUPS			TRIM GROUPS					SEAL GROUPS				
	1	2	3	01*	02	03	04	05	S01	S02	F02	M01	
Phosphoric Acid, 50% hot	D	D	D	D	D	D	C	D	A	A	D	D	
Phosphoric Acid, 85% cold	B	A	B	B	B	A	A	B	A	A	A	A	
Phosphoric Acid, 85% hot	C	A	C	C	C	A	A	C	A	A	A	A	
Phthalic Acid	C	B	C	C	B	A	A	B	A	-	B	B	
Phthalic Anhydride	C	B	C	C	B	B	C	B	A	A	B	B	
Picric Acid	C	B	C	C	B	B	A	B	A	A	B	B	
Pine Oil	B	A	B	B	A	A	A	A	A	A	A	A	
Potassium Bisulfite, 10%	D	B	D	D	B	B	D	B	A	A	B	B	
Potassium Bromide	D	B	D	D	B	B	B	B	A	A	B	B	
Potassium Carbonate	C	A	C	B	A	A	B	A	A	A	A	A	
Potassium Chlorate	B	A	B	B	A	A	A	B	A	A	A	A	
Potassium Chloride	C	C	C	C	C	B	C	A	A	C	C	C	
Potassium Cyanide	B	B	B	B	B	B	B	B	A	A	B	B	
Potassium Dichromate	B	A	B	B	A	A	B	A	A	A	A	A	
Potassium Diphosphate	A	A	A	A	A	A	B	A	A	A	A	A	
Potassium Ferricyanide	B	B	B	B	B	B	B	B	A	A	B	B	
Potassium Ferrocyanide	B	B	B	B	B	B	B	B	A	A	B	B	
Potas. Hydrox. dilute, cold	B	B	B	B	B	B	B	A	B	A	B	B	
Potas. Hydrox. dilute, hot	B	A	B	B	B	A	A	B	A	B	B	A	
Potas. Hydrox. to 70%	A	A	A	A	A	A	A	A	A	B	B	A	
Potassium Iodide	C	B	C	C	B	B	B	B	A	A	B	B	
Potassium Nitrate	B	A	B	B	A	A	A	A	A	A	A	A	
Potassium Permanganate	A	A	A	A	A	A	B	A	A	A	A	A	
Potassium Sulfate	B	B	B	B	B	B	B	B	A	A	B	B	
Potassium Sulfide, 10%	C	B	C	B	B	B	D	B	A	A	B	B	
Potassium Sulfite, 10%	D	B	D	D	B	B	D	B	A	A	B	B	
Producer Gas	B	B	B	B	B	B	A	B	A	A	B	B	
Propane	A	A	A	A	A	A	A	A	A	A	A	A	
Propyl Alcohol	A	A	A	A	A	A	A	A	A	A	A	A	
Propylene Glycol	A	A	A	A	A	A	A	A	A	A	A	A	
Pyrogalic Acid	B	B	B	B	B	B	B	B	A	A	B	B	
Quench Oil, water soluble	A	A	A	A	A	A	A	A	A	A	A	A	
Resins and Rosins	C	A	C	B	A	A	A	A	A	A	A	A	
Road Tar	A	A	A	A	A	A	A	A	A	A	A	A	
Road Pitch	A	A	A	A	A	A	A	A	A	A	A	A	
RP-1 Fuel	A	A	A	A	A	A	A	A	A	A	A	A	
Rubber latex emulsions	B	A	B	B	A	A	A	A	A	A	A	A	
Rubber Solvent	A	A	A	A	A	A	A	A	A	A	A	A	
Salad Oil	C	B	C	B	B	B	B	B	A	A	B	B	
Salicylic Acid	D	A	D	D	A	A	A	A	A	A	A	A	
Salt	C	B	C	C	B	B	A	B	A	A	B	B	
Seawater	D	A	D	C	A	A	A	A	A	A	A	A	
Shellac	A	A	A	A	A	A	A	A	A	A	A	A	
Silicone Oils	A	A	A	A	A	A	A	A	A	A	A	A	
Silver Nitrate	D	B	D	D	B	B	D	B	A	A	B	B	
Soap Solutions, stearates	A	A	A	A	A	A	A	A	A	A	A	A	
Sodium Acetate	B	B	B	B	B	B	B	B	A	A	B	B	
Sodium Aluminate	C	A	C	C	A	A	A	A	A	A	A	A	
Sodium Bicarbonate	C	B	C	C	B	B	B	B	A	A	B	B	
Sodium Bisulfate, 10%	D	A	D	D	A	A	B	A	A	A	A	A	
Sodium Bisulfite, 10%	D	D	D	D	D	B	D	A	A	A	D	D	
Sodium Borate	C	D	C	D	D	B	D	A	A	A	D	D	
Sodium Bromide, 10%	C	B	C	C	B	B	B	B	A	A	B	B	
Sodium Carbonate	B	B	B	B	B	B	A	B	A	A	B	B	
Sodium Chlorate	C	B	C	C	B	B	B	B	A	A	B	B	
Sodium Chloride	C	B	C	B	B	B	A	B	A	A	B	B	

Note: All ladings at ambient temperatures except as noted.

* Size 14 in. (350 mm) and larger, Class 150/300 valves are available with CS trim.

MATERIAL SELECTION GUIDE (CONTINUED)

LADINGS	MATERIALS OF CONSTRUCTION												
	BODY GROUPS			TRIM GROUPS					SEAL GROUPS				
	1	2	3	01*	02	03	04	05	S01	S02	F02	M01	
Sodium Chromate	B	B	B	B	B	B	B	B	A	A	B	B	
Sodium Cyanide, 10%	A	A	A	C	A	A	B	A	A	A	A	A	
Sodium Fluoride	D	B	D	D	B	B	A	B	A	A	B	B	
Sodium Hydrox., cold 20%	A	A	A	A	A	A	A	A	A	A	A	A	
Sodium Hydrox., hot 20%	C	B	C	C	B	B	A	B	A	B	B	B	
Sodium Hydrox. 50%	B	B	B	B	B	B	A	B	A	C	C	B	
Sodium Hydrox., cold 70%	C	B	C	B	B	B	B	B	A	C	C	B	
Sodium Hydrox., hot 70%	B	B	B	B	B	B	B	B	A	D	D	B	
Sodium Hypochlorite	D	D	D	D	D	D	D	D	A	A	D	D	
Sodium Metaphosphate	A	B	A	A	B	B	B	B	A	A	B	B	
Sodium Metasilicate, cold	C	A	C	C	A	A	A	A	A	A	A	A	
Sodium Metasilicate, hot	D	A	D	D	A	A	A	A	A	A	A	A	
Sodium Nitrate	B	B	B	B	B	B	B	B	A	A	B	B	
Sodium Perborate	B	B	B	B	B	B	B	B	A	A	B	B	
Sodium Peroxide	C	B	C	C	B	B	B	B	A	A	B	B	
Sodium Phosphate	B	B	B	B	B	B	B	B	A	A	B	B	
Sodium Silicate	A	A	A	A	A	A	B	A	A	A	A	A	
Sodium Silicate, hot	B	B	B	B	B	B	B	B	A	A	B	B	
Sodium Sulfate	B	A	B	B	A	A	A	A	A	A	A	A	
Sodium Sulfide	B	B	B	B	B	B	A	B	A	A	B	B	
Sodium Sulfide, hot	C	B	C	C	B	B	B	B	A	A	B	B	
Sodium Thiosulfate	D	B	D	D	B	B	B	B	A	A	B	B	
Sour Gas and Oil	Consult Factory												
Soybean Oil	C	A	C	C	A	A	A	A	A	A	A	A	
Stannic Chloride	D	D	D	D	D	D	C	D	A	A	D	D	
Stannous Chloride	D	C	D	D	C	C	A	C	A	-	-	-	
Starch	A	A	A	A	A	A	A	A	A	A	A	A	
Steam, 212°F	A	A	A	A	A	A	A	A	A	A	A	A	
Stearic Acid	C	A	C	B	A	A	B	A	A	A	A	A	
Stoddard Solvent	B	B	B	B	B	B	B	B	A	A	B	B	
Styrene	A	A	A	A	A	A	A	A	A	A	A	A	
Sugar Liquids	B	A	B	B	B	A	A	B	A	A	A	A	
Sulfate, black or gr. liq.	C	B	C	C	B	B	B	B	A	A	B	B	
Sulfate, white liquor	D	B	D	D	D	B	B	D	A	A	B	B	
Sulphur	B	A	B	B	A	A	A	A	A	A	A	A	
Sulphur Dioxide, dry	B	A	B	D	D	A	A	D	A	A	A	A	
Sulphur Trioxide, dry	B	B	B	B	B	B	B	B	A	A	B	B	
Sulfuric Acid, 0-7%	D	B	D	D	C	B	B	C	A	A	B	B	
Sulfuric Acid, 20-50%	D	D	D	D	D	D	B	D	A	A	B	B	
Sulfuric Acid, 100%	B	A	B	D	C	A	A	C	A	A	A	A	
Sulfurous Acid	D	D	D	D	D	D	D	D	A	A	D	D	
Synthesis Gas	B	B	B	B	B	B	A	B	A	A	B	B	
Tall Oil	B	B	B	B	B	B	A	B	A	A	B	B	
Tannic Acid	B	B	B	B	B	B	B	B	A	A	B	B	
Tar and Tar Oil	A	A	A	A	A	A	A	A	A	A	A	A	
Tartaric Acid	D	B	D	D	B	B	B	B	A	A	B	B	
Tetraethyl Lead	C	B	C	C	B	B	A	B	A	A	B	B	
Toluene, Toluol	A	A	A	A	A	A	A	A	A	A	A	A	
Tomato Juice	C	A	C	C	A	A	A	A	A	A	A	A	
Transformer Oil	A	A	A	A	A	A	A	A	A	A	A	A	
Tributyl Phosphate	A	A	A	A	A	A	A	A	A	A	A	A	
Trichloroethylene	B	B	B	B	B	B	A	B	A	A	B	B	
Turpentine	B	A	B	A	A	A	B	A	A	A	A	A	
Urea	C	B	C	C	B	B	A	B	A	A	B	B	
Varnish	C	A	C	C	A	A	A	A	A	A	A	A	
Vegetable Oil	B	A	B	A	A	A	B	A	A	A	A	A	

LADINGS	MATERIALS OF CONSTRUCTION												
	BODY GROUPS			TRIM GROUPS					SEAL GROUPS				
	1	2	3	01*	02	03	04	05	S01	S02	F02	M01	
Vinegar	D	A	D	D	A	A	A	A	A	A	A	A	
Vinyl Chloride	D	B	D	D	C	B	A	C	A	A	A	B	
Water, distilled (aerated)	D	A	D	B	A	A	A	A	A	A	A	A	
Water, fresh	C	A	C	B	A	A	A	A	A	A	A	A	
Waxes	A	A	A	A	A	A	A	A	A	A	A	A	
Whiskey and Wine	D	A	D	B	A	A	A	A	A	A	A	A	
Xylene, dry	A	A	A	A	A	A	A	A	A	A	A	A	
Zinc Chloride	D	D	D	D	D	D	B	D	A	A	D	D	
Zinc Hydrosulfite	A	A	A	A	A	A	B	A	A	A	A	A	
Zinc Sulfate	D	B	D	D	D	B	B	D	A	A	B	B	

Note: All ladings at ambient temperatures except as noted.

* Size 14 in. (350 mm) and larger, Class 150/300 valves are available with CS trim.

TRADEMARK INFORMATION

WKM® is a registered trademark which is owned by Cameron.

This document contains references to registered trademarks or product designations, which are not owned by Cameron.

Trademark	Owner	Common Name	Comparable Cameron Abbreviated Name (in Trim Charts)		
Aflas	Asahi Glass Company	TFE Propylene	FXM		
Celcon	Hoechst Celanese Corporation				
Delrin	E.I. DuPont De Nemours & Company				
Inconel	INCO Nickel Sales, Inc.				
Monel	INCO Alloys International, Inc.	Polyetheretherketone	PK		
PEEK	Victrex PLC Corp United Kingdom				
Stellite	Stoody Deloro Stellite, Inc.				
Teflon	E.I. Dupont De Nemours & Company				
Viton	Dupont Dow Elastomers L.L.C.				
17-4PH	Armco Advanced Materials Corp.			17-4PH Stainless Steel	Type 630
				Electroless Nickel Plating	ENP

**VALVES & MEASUREMENT**

3250 Briarpark Drive, Suite 300
Houston, Texas 77042
USA Toll Free 800 323 9160

For the most current contact and location information go to: www.c-a-m.com/valvesandmeasurement